



당첨되시계



201411212 송인호
201611234 전재원
201611230 전계원
201711809 박수빈

[2041] Design Real Use Cases

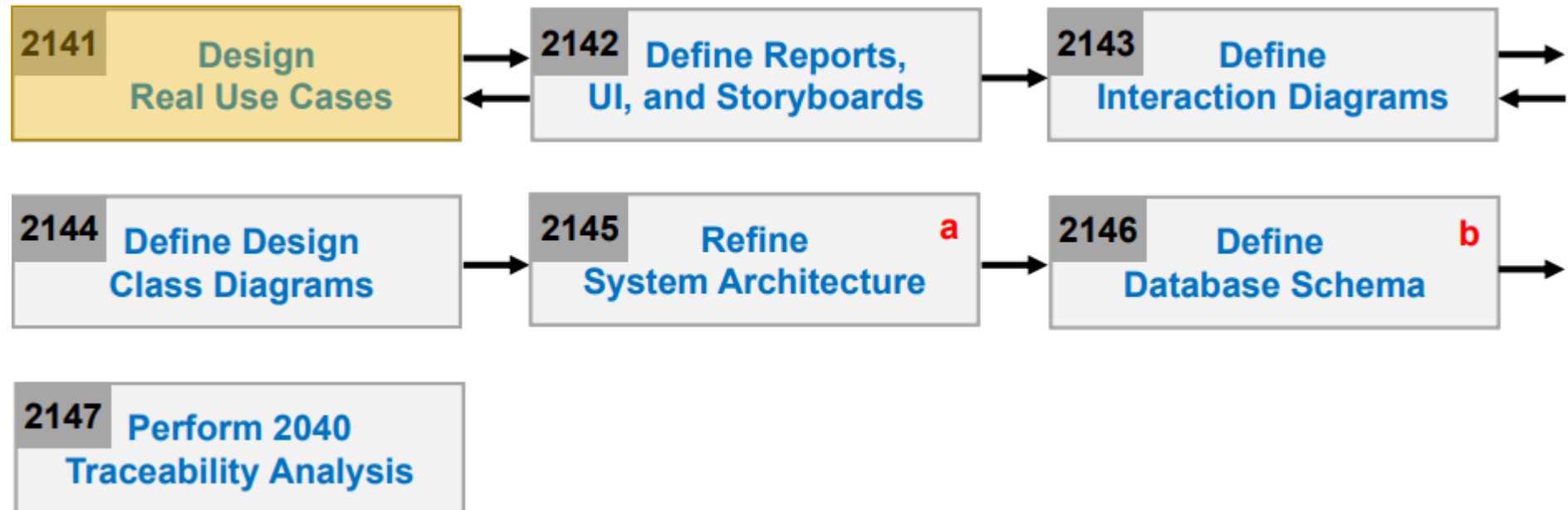

Use Case	1. Set Timer
Actor	User
Type	Evident
Pre-Requisites	현재 모드가 Timer 이어야 한다. runningFlag 가 false이어야 한다.
Typical Courses of Events	(A): Actor, (S): System 1. (A) Adjust 버튼 을 누른다. 2. (S) isEditing 을 true로 설정한다. editingIdx 를 0으로 설정한다. 3. (A) '+' 버튼 혹은 '-' 버튼 으로 해당 자리의 값을 수정한다. 4. (S) 변경된 값에 대하여 tempTime 을 변경한다. 5. (A) Adjust 버튼 을 눌러서 다음 순서로 넘어간다. 순서는 시, 분, 초로 각각 2자리씩 설정한다. 6. (S) editingIdx 를 1증가시킨다. 7. (A) 3~6을 editingIdx 가 6이 될 때까지 반복한다. 8. (S) tempTime 에 맞게 settingTime 과 timestamp 를 설정한다. 9. (S) isEditing 을 false로 설정한다.
Alternative Courses of Events	E3. 시간을 설정할 때 시, 분, 초가 각각의 최대값 보다 크게 설정된다면 0으로, 최소 범위보다 작게 설정된다면 최대값으로 설정한다.
Exceptional Courses Of Events	E2~8. Mode 버튼 을 누르면 isEditing 을 false로 설정한다.

Use Case	2. Start Timer
Actor	User
Type	Evident
Pre-Requisites	현재 모드가 Timer 이어야 한다. runningFlag 가 false이어야 한다.
Typical Courses of Events	(A): Actor, (S): System 1. (A) '+' 버튼을 누른다. 2. (S) runningFlag 를 true로 변경한다.
Alternative Courses of Events	N/A
Exceptional Courses Of Events	N/A

Use Case	3. Pause Timer
Actor	User
Type	Evident
Pre-Requisites	현재 모드가 Timer 이어야 한다. runningFlag 가 true이어야 한다.
Typical Courses of Events	(A): Actor, (S): System 1. (A) '+' 버튼을 누른다. 2. (S) runningFlag 를 false로 변경한다.
Alternative Courses of Events	N/A
Exceptional Courses Of Events	N/A

Use Case	4. Reset Timer
Actor	User
Type	Evident
Pre-Requisites	현재 모드가 Timer 이어야 한다. runningFlag 가 false이어야 한다.
Typical Courses of Events	(A): Actor, (S): System 1. (A) '-' 버튼을 누른다. 2. (S) timestamp 을 settingTime 의 값으로 변경한다.
Alternative Courses of Events	N/A
Exceptional Courses Of Events	N/A

Use Case	5. Check Timer
Actor	None
Type	Hidden
Pre-Requisites	선택 된 4개의 모드 중 Timer 가 있어야 한다. runningFlag 가 true이어야 한다.
Typical Courses of Events	(S): System 1. (S) timestamp 에 저장되어 있는 시간을 매 초 갱신해준다. 2. (S) timestamp 의 값이 0이 될 때 runningFlag 를 false로 변경하고 buzzerOn 을 true로 변경한다.
Alternative Courses of Events	N/A
Exceptional Courses Of Events	N/A

Use Case	6. Ring Timer
Actor	None
Type	Hidden
Pre-Requisites	선택 된 4개의 모드 중 Timer 가 있어야 한다. buzzerOn 이 true이어야 한다.
Typical Courses of Events	(S): System 1. (S) buzzer를 울린다.
Alternative Courses of Events	N/A
Exceptional Courses Of Events	N/A

Use Case	7. Stop Ring Timer
Actor	User
Type	Evident
Pre-Requisites	선택 된 4개의 모드 중 Timer 가 있어야 한다. buzzerOn 이 true이어야 한다.
Typical Courses of Events	(A): Actor, (S): System 1. (A) 아무 버튼을 누른다. 2. (S) buzzer를 멈춘다. 3. (S) buzzerOn 을 false로 변경한다. 4. (S) timestamp 의 값을 settingTime 값으로 변경한다.
Alternative Courses of Events	N/A
Exceptional Courses Of Events	N/A

Use Case	8. Show Timer
Actor	None
Type	Hidden
Pre-Requisites	현재 모드가 timer 이어야 한다.
Typical Courses of Events	<p>(S): System</p> <ol style="list-style-type: none"> (S) 현재 수정 중인지 isEditing을 확인한다. (S) isEditing이 true라면 Top에 "Timer"를, Bottom에 tempTime을 출력하고, false라면 timestamp을 출력합니다. (S) isEditing이 true이고, 현재 초를 tickInterval로 나눈 나머지가 0이라면 editingIdx에 해당하는 자리를 출력하지 않습니다. (깜빡임) (S) isEditing이 false이고, 현재 초를 tickInterval으로 나눈 나머지가 0이라면 Bottom의 3, 6번째 위치에 ":"을 출력합니다.
Alternative Courses of Events	N/A
Exceptional Courses Of Events	N/A

Use Case	9. Set Alarm
Actor	User
Type	Evident
Pre-Requisites	현재 모드가 Alarm 이어야 한다.
Typical Courses of Events	<p>(A): Actor, (S): System</p> <ol style="list-style-type: none"> 1. (A) Adjust 버튼을 누른다. 2. (S) tempTime을 alarmInfoArr의 curAlarmIdx번째 데이터의 timestamp 값으로 초기화한다. (초는 0으로 설정한다) 3. (S) isEditing을 true로 설정한다. editingIdx를 1으로 설정한다. 4. (A) '+' 혹은 '-' 버튼으로 해당 자리의 값을 1씩 더하거나 빼며 수정한다.. 5. (A) Adjust 버튼을 눌러 다음 순서로 넘어간다. 6. (S) 변경된 값에 대하여 tempTime을 변경한다. 7. (S) editingIdx를 1 만큼 증가시킨다. 8. (A) 4~7을 editingIdx가 4가 될 때 까지 반복한다. 9. (S) isEditing을 false로 설정한다. alarmInfoArr의 curAlarmIdx번째 데이터의 timestamp를 tempTime값으로 변경한다.
Alternative Courses of Events	E4. 시간을 설정할 때 시, 분, 초가 각각의 최대값 보다 크게 설정된다면 0으로, 최소 범위보다 작게 설정된다면 최대값으로 설정한다.
Exceptional Courses Of Events	E2~8. Mode 버튼 을 누르면 isEditing 을 false로 설정한다.

Use Case	10. On Alarm
Actor	User
Type	Evident
Pre-Requisites	현재 모드가 Alarm 이어야 한다. alarmInfoArr 의 curAlarmIdx 번째 데이터의 isOn 값이 false여야 한다.
Typical Courses of Events	<p>(A): Actor, (S): System</p> <ol style="list-style-type: none"> 1. (A) '-' 버튼을 누른다. 2. (S) 해당 알람의 isOn을 true으로 변경한다
Alternative Courses of Events	N/A
Exceptional Courses Of Events	N/A

Use Case	11. Off Alarm
Actor	User
Type	Evident
Pre-Requisites	현재 모드가 Alarm 이어야 한다. alarmInfoArr 의 curAlarmIdx 번째 데이터의 isOn 값이 true여야 한다.
Typical Courses of Events	(A): Actor, (S): System 1. (A) '-' 버튼을 누른다. 2. (S) 해당 알람의 isOn 을 false으로 변경한다
Alternative Courses of Events	N/A
Exceptional Courses Of Events	N/A

Use Case	12. Next Alarm
Actor	User
Type	Evident
Pre-Requisites	현재 모드가 Alarm 이어야 한다.
Typical Courses of Events	<p>(A): Actor, (S): System</p> <ol style="list-style-type: none"> 1. (A) '+' 버튼을 누른다. 2. (S) curAlarmIdx 값을 1만큼 증가시킨다.
Alternative Courses of Events	E2. 증가된 curAlarmIdx 의 값이 alarmInfoArr 의 길이와 같거나 크다면 curAlarmIdx 를 0으로 초기화한다.
Exceptional Courses Of Events	N/A

Use Case	13. Show Alarm
Actor	None
Type	Hidden
Pre-Requisites	현재 모드가 Alarm 이어야 한다.
Typical Courses of Events	<p>(A): Actor, (S): System</p> <ol style="list-style-type: none"> 1. (S) 현재 수정 중인지 isEditing을 확인한다. 2. (S) isEditing이 true라면, Bottom에 tempTime의 시, 분을 출력하고, false라면 alarmInfoArr의 curAlarmIdx번째 데이터의 timestamp을 출력한다. 3. (S) isEditing이 true이고, 현재 초를 tickInterval로 나눈 나머지가 0이라면 editingIdx에 해당하는 자리를 출력하지 않습니다. 4. (S) isEditing이 false이고, 현재 초를 tickInterval로 나눈 나머지가 0이라면 Bottom에 3번째 칸에 ":"을 출력합니다 5. (S) alarmInfoArr의 curAlarmIdx번째 알람의 isOn 값이 true라면 Top에 "ON"을 출력하고, isOn값이 false라면 Top에 "OFF"를 출력한다.
Alternative Courses of Events	N/A
Exceptional Courses Of Events	N/A

Use Case	14. Check Alarm
Actor	None
Type	Hidden
Pre-Requisites	선택 된 4개의 모드 중 Alarm 가 있어야 한다.
Typical Courses of Events	<p>(A): Actor, (S): System</p> <ol style="list-style-type: none"> (S) isOn 값이 true인 알람들의 시간과 GlobalSettings의 timestamp와 비교한다. (S) 울릴 시간이라면, buzzerOn 값을 true로 변경한다. (S) 해당 알람의 isOn을 false로 설정한다.
Alternative Courses of Events	N/A
Exceptional Courses Of Events	N/A

Use Case	15. Ring Alarm
Actor	None
Type	Hidden
Pre-Requisites	선택 된 4개의 모드 중 Alarm 가 있어야 한다. buzzerOn 이 true이어야 한다.
Typical Courses of Events	(A): Actor, (S): System 1. (S) buzzer를 울린다.
Alternative Courses of Events	N/A
Exceptional Courses Of Events	N/A

Use Case	16. Stop Ring Alarm
Actor	User
Type	Evident
Pre-Requisites	선택 된 4개의 모드 중 Alarm 가 있어야 한다. buzzerOn 이 true어야 한다.
Typical Courses of Events	(A): Actor, (S): System 1. (A) 아무 버튼을 누른다. 2. (S) buzzer을 멈춘다. 3. (S) buzzerOn 을 false로 변경한다.
Alternative Courses of Events	N/A
Exceptional Courses Of Events	N/A

Use Case	17. Start Stopwatch
Actor	User
Type	Evident
Pre-Requisites	현재 모드가 Stopwatch 모드이어야 한다. runningFlag 값이 false이어야 한다
Typical Courses of Events	(A): Actor, (S): System 1. (A) '+' 버튼을 누른다 2. (S) runningFlag 값을 true로 바꾼다
Alternative Courses of Events	N/A
Exceptional Courses Of Events	N/A

Use Case	18. Pause Stopwatch
Actor	User
Type	Evident
Pre-Requisites	현재 모드가 Stopwatch 모드이어야 한다. runningFlag 값이 true이어야 한다.
Typical Courses of Events	(A): Actor, (S): System 1. (A) '+' 버튼을 누른다 2. (S) runningFlag 값을 false로 바꾼다
Alternative Courses of Events	N/A
Exceptional Courses Of Events	N/A

Use Case	19. Reset Stopwatch
Actor	User
Type	Evident
Pre-Requisites	현재 모드가 Stopwatch 모드이어야 한다. runningFlag 값이 false이어야 한다
Typical Courses of Events	(A): Actor, (S): System 1. (A) '-' 버튼을 누른다 2. (S) timestampRecord 와 timestamp 값을 0으로 바꾼다
Alternative Courses of Events	N/A
Exceptional Courses Of Events	N/A

Use Case	20. Record Lap
Actor	User
Type	Evident
Pre-Requisites	현재 모드가 Stopwatch 모드이어야 한다.
Typical Courses of Events	<p>(A): Actor, (S): System</p> <ol style="list-style-type: none"> 1. (A) Adjust 버튼을 누른다 2. (S) timestamp 값을 timestampRecord에 저장한다
Alternative Courses of Events	N/A
Exceptional Courses Of Events	N/A

Use Case	21. Run Stopwatch
Actor	None
Type	Hidden
Pre-Requisites	선택 된 4개의 모드 중 Stopwatch 가 있어야 한다.
Typical Courses of Events	<p>(A): Actor, (S): System</p> <ol style="list-style-type: none"> 1. (S) timestamp에 저장되어 있는 시간을 매 초 갱신해준다
Alternative Courses of Events	N/A
Exceptional Courses Of Events	N/A

Use Case	22. Show Stopwatch
Actor	None
Type	Hidden
Pre-Requisites	현재 모드가 Stopwatch 모드이어야 한다.
Typical Courses of Events	<p>(A): Actor, (S): System</p> <ol style="list-style-type: none"> 1. (S) timestamp을 Bottom에 출력한다. 2. (S) timestampRecord를 Top에 출력한다. 3. (S) timestamp을 tickInterval으로 나눈 나머지가 0이라면 Bottom의 3, 6번째 칸에 ":"을 출력한다.
Alternative Courses of Events	N/A
Exceptional Courses Of Events	N/A

Use Case	23. Timezone to right
Actor	User
Type	Evident
Pre-Requisites	현재 모드가 WorldTime 이어야 한다.
Typical Courses of Events	<p>(A): Actor, (S): System</p> <ol style="list-style-type: none"> 1. (A) 사용자가 '+' 버튼을 누른다. 2. (S) timezoneldx를 1만큼 증가시킨다.
Alternative Courses of Events	E2. timezoneldx 를 timezoneList 의 길이로 나눈 값의 나머지로 설정한다.
Exceptional Courses Of Events	N/A

Use Case	24. Timezone to left
Actor	User
Type	Evident
Pre-Requisites	현재 모드가 WorldTime 이어야 한다.
Typical Courses of Events	<p>(A): Actor, (S): System</p> <ol style="list-style-type: none"> 1. (A) 유저가 '-' 버튼을 누른다. 2. (S) timezoneldx를 1만큼 감소시킨다.
Alternative Courses of Events	E2. timezoneldx 에 timezoneList 의 길이만큼 더하고, timezoneList 의 길이로 나눈 값의 나머지로 설정한다.
Exceptional Courses Of Events	N/A

Use Case	25. Show Worldtime
Actor	None
Type	Hidden
Pre-Requisites	현재 모드가 WorldTime 이어야 한다.
Typical Courses of Events	<p>(A): Actor, (S): System</p> <ol style="list-style-type: none"> (S) timezoneldx의 값이 범위 내에 있는지 확인합니다 (S) timezoneList의 timezoneldx번째 데이터가 존재하는지 확인합니다. 존재하지 않는다면 빈 문자열("")을 사용합니다. (S) Top에 시간대와 대표도시를 출력합니다. Bottom에 GlobalSettings의 timestamp에 시간대를 적용한 시간을 출력합니다.
Alternative Courses of Events	E1. timezoneldx 가 0 미만이라면, 0이 될 때까지 (timezoneList 의 길이)만큼 더합니다. timezoneldx 가 timezoneList 의 길이와 같거나 클 경우, (timezoneList 의 길이)로 나눈 값의 나머지 값으로 설정합니다.
Exceptional Courses Of Events	N/A

Use Case	26. Set TimeKeeping
Actor	User
Type	Evident
Pre-Requisites	현재 모드가 TimeKeeping 이어야 한다.
Typical Courses of Events	<p>(A): Actor, (S): System</p> <ol style="list-style-type: none"> (A) Adjust 버튼을 누른다. (S) isEditing을 true로 설정한다. editingIdx를 0으로 설정하고, tempTime를 현재 시간으로 초기화한다. (A) '+' 버튼 혹은 '-' 버튼을 통해 해당 자리의 값을 수정한다. (S) 변경된 값에 대하여 tempTime을 변경한다. (A) Adjust 버튼을 눌러서 다음 순서로 넘어간다. (S) editingIdx를 1 증가시킨다 (A) 3~6를 editingIdx가 9가 될 때까지 (=마지막 자리(초의 1의 자리))까지 반복한다. (S) GlobalSettings의 timestamp를 tempTime으로 설정한다. (S) isEditing을 false로 설정한다.
Alternative Courses of Events	E4. 시간을 설정할 때 시, 분, 초가 각각의 최대값 보다 크게 설정된다면 0으로, 최소 범위보다 작게 설정된다면 최대값으로 설정한다.
Exceptional Courses Of Events	E2~7. Mode 버튼 을 누르면 isEditing 을 false로 설정한다.

Use Case	27. Show TimeKeeping
Actor	None
Type	Hidden
Pre-Requisites	현재 모드가 TimeKeeping 이어야 한다.
Typical Courses of Events	<p>(A): Actor, (S): System</p> <ol style="list-style-type: none"> (S) 현재 수정 중인지 isEditing을 확인합니다. (S) isEditing이 true이고, 현재 초를 tickInterval로 나눈 나머지가 0이라면 editingIdx에 해당하는 자리를 출력하지 않습니다. (깜박임) (S) isEditing이 false이고, 현재 초를 tickInterval으로 나눈 나머지가 0이라면 Bottom의 3, 6번째 칸에 ":"를 출력합니다. (깜박임) (S) Top에는 "??:??:??"형식으로 출력합니다. ??은 앞에서부터 년, 월, 일입니다. Bottom에는 "??:??:??"형식으로 출력합니다. ??은 앞에서부터 시, 분, 초입니다.
Alternative Courses of Events	N/A
Exceptional Courses Of Events	N/A

Use Case	28. Start Lottery
Actor	User
Type	Evident
Pre-Requisites	현재 모드가 Lottery 어야 한다. isStarted 가 false여야한다.
Typical Courses of Events	(A): Actor, (S): System 1. (A) '+' 버튼을 누른다. 2. (S) isStarted 값을 true로 설정한다. 3. (S) lotteryArr 의 1~45사이의 값을 중복되지않게 넣은 후, 오름차순으로 정렬한다
Alternative Courses of Events	N/A
Exceptional Courses Of Events	N/A

Use Case	29. Reset Lottery
Actor	User
Type	Evident
Pre-Requisites	현재 모드가 Lottery 어야 한다.
Typical Courses of Events	<p>(A): Actor, (S): System</p> <ol style="list-style-type: none"> 1. (A) '-' 버튼을 누른다. 2. (S) isStarted값을 false로 설정한다.
Alternative Courses of Events	N/A
Exceptional Courses Of Events	N/A

Use Case	30. Show Lottery
Actor	None
Type	Hidden
Pre-Requisites	현재 모드가 Lottery 어야 한다.
Typical Courses of Events	<p>(A): Actor, (S): System</p> <ol style="list-style-type: none"> 1. (S) isStarted의 값이 true라면, TOP에 lotteryArr 0~2번째 숫자를 출력하고, BOTTOM에 3~5번째 숫자를 출력한다. 2. (S) isStarted의 값이 false라면, TOP에 "Start", BOTTOM에 "LOTTERY"를 출력한다.
Alternative Courses of Events	N/A
Exceptional Courses Of Events	N/A

Use Case	31. Set Mode Selection
Actor	User
Type	Evident
Pre-Requisites	<p>현재 모드가 다음 조건들 중 하나를 만족한다.</p> <ul style="list-style-type: none"> - isEditing이 false인 Timer, TimeKeeping, Alarm 모드 - Stopwatch, WorldTime, Lottery 모드
Typical Courses of Events	<p>(A): Actor, (S): System</p> <ol style="list-style-type: none"> 1. (A) Mode 버튼을 길게 누른다. 2. (S) GlobalSettings의 curMode를 Mode Selection 모드로 변경한다. 3. (S) modeIdx를 0으로 설정한 후 GlobalSettings의 modes 배열 값을 tempModes 배열과 tempModesCpy 배열에 복사한다 4. (A) '+' 버튼을 누른다. 5. (S) tempModesCpy의 modeIdx번째 값이 1 증가한다. 6. (A) '-' 버튼을 누른다. 7. (S) tempModesCpy의 modeIdx번째 값이 1 감소한다. 8. (A) Adjust 버튼을 누를 때까지 4~7을 반복한다. 9. (S) tempModesCpy의 모든 값을 tempModes에 저장하고, modeIdx의 값을 1 증가한다 10. (S) modeIdx의 값이 4가 될 때까지 4~9을 반복한다. 11. (S) tempModes 값을 GlobalSettings의 modes 배열에 저장한다.
Alternative Courses of Events	<p>E5. tempModesCpy의 modeIdx번째 값이 5 이상이면, 해당 값을 0으로 변경한다. E7. tempModesCpy의 modeIdx번째 값이 0 이하이면, 해당 값을 5으로 변경한다. E8. 수정된 tempModesCpy의 modeIdx번째 값이 tempModesCpy의 modeIdx번째를 제외한 다른 위치에 있는 값일 경우, 두 자리의 값을 스왑한다.</p>
Exceptional Courses Of Events	<p>E3~10사이에 Mode 버튼을 눌렀을 경우, GlobalSettings의 curMode를 0으로 변경한다</p>

Use Case	32. Show Mode Selection
Actor	System
Type	Hidden
Pre-Requisites	현재 모드가 Mode Selection 어야 한다.
Typical Courses of Events	<p>(S): System</p> <ol style="list-style-type: none"> (S) Top에 "Mode"를 출력하고, tempModes 배열에 해당하는 값들을 Bottom에 출력한다. (S) 현재 초를 tickInterval로 나눈 나머지가 0이라면 curMode에 해당하는 자리를 출력하지 않습니다.
Alternative Courses of Events	N/A
Exceptional Courses Of Events	N/A

Use Case	33. Change Mode
Actor	User
Type	Evident
Pre-Requisites	Mode 버튼을 눌렀을 때, 다른 이벤트에 처리되지 않은 경우
Typical Courses of Events	<p>(A): Actor, (S): System</p> <ol style="list-style-type: none"> 1. (A) Mode 버튼을 누른다. 2. (S) GlobalSettings의 curMode의 값을 +1 해준다.
Alternative Courses of Events	E2. curMode 가 modes 의 길이와 같거나 크다면 0으로 변경한다.
Exceptional Courses Of Events	N/A

Use Case	34. Time Checkout
Actor	None
Type	Hidden
Pre-Requisites	어떠한 버튼도 누르지 않은 채 일정시간 이상 지나야 한다.
Typical Courses of Events	<p>(S): System</p> <ol style="list-style-type: none"> 1. (S) GlobalSettings의 curMode값을 Default Screen으로 변경한다. 2. (S) noActionTime을 0으로 변경한다.
Alternative Courses of Events	N/A
Exceptional Courses Of Events	N/A

[2042] Define Draft System Architecture

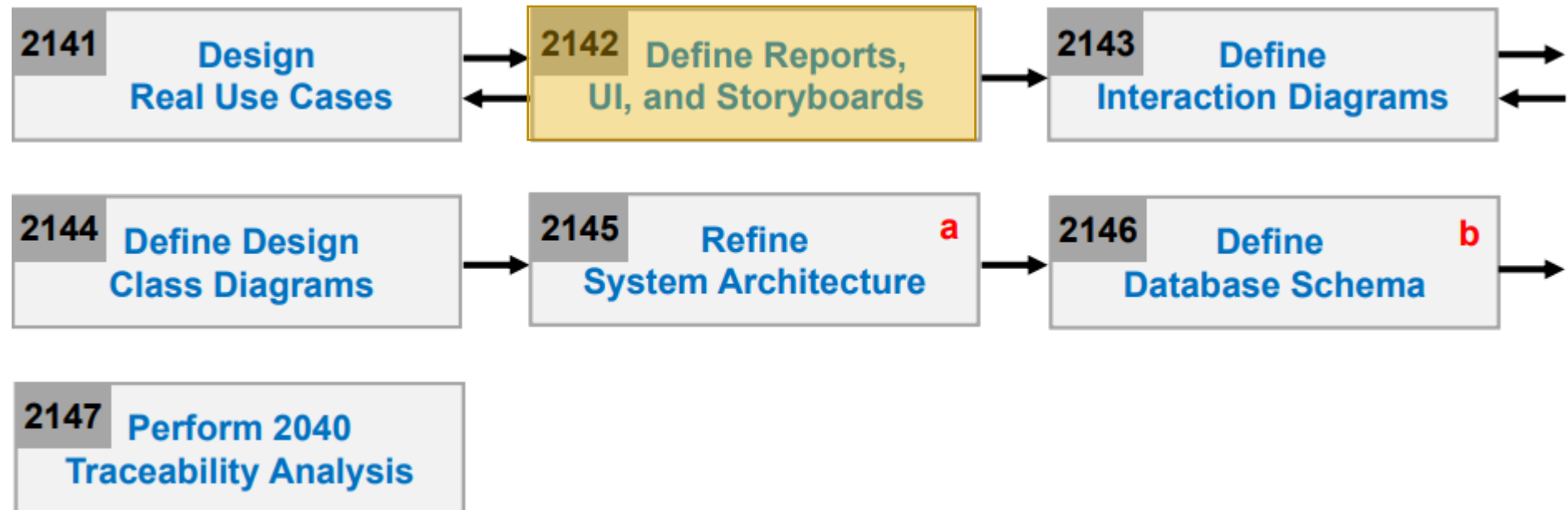

1. Timer

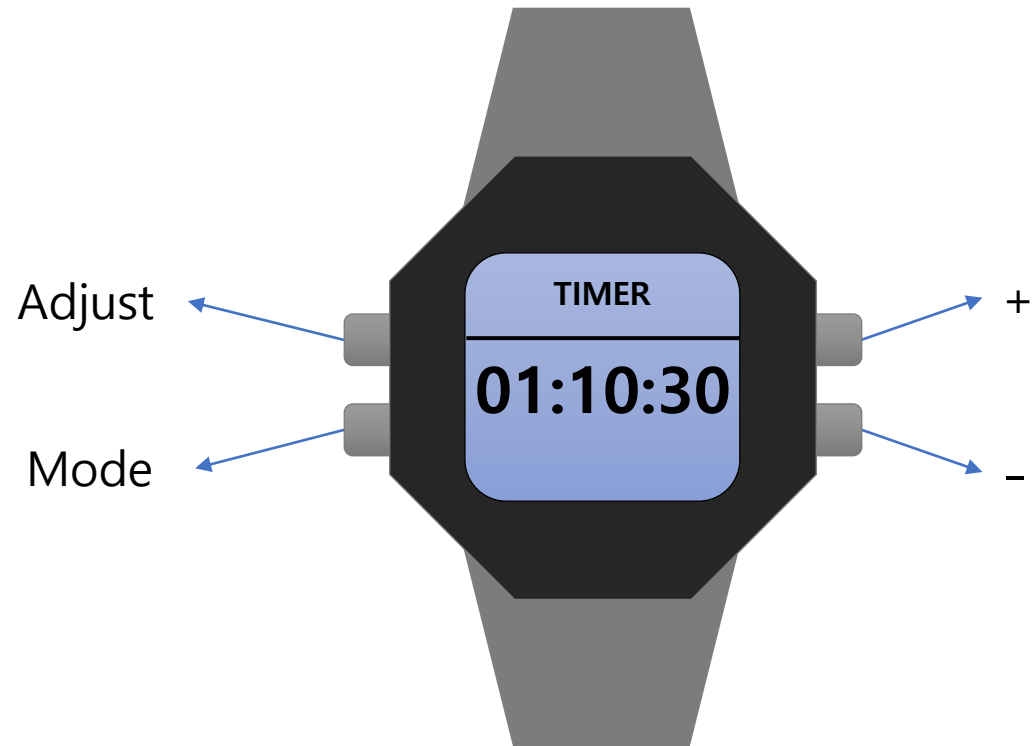

2. Alarm

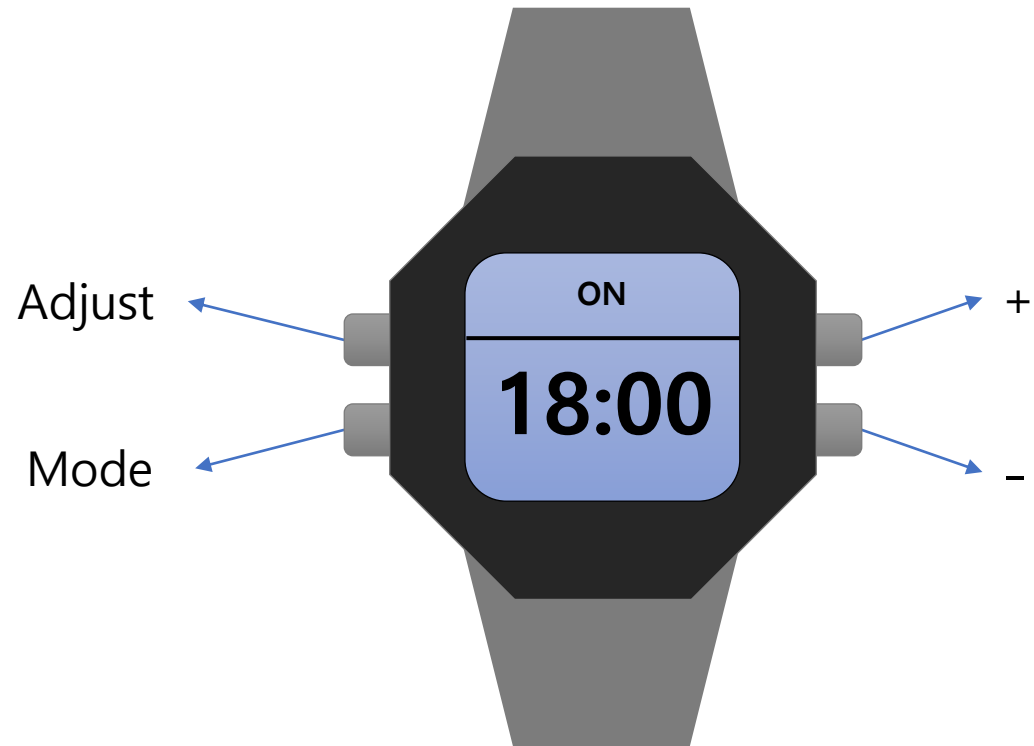

3. Stopwatch

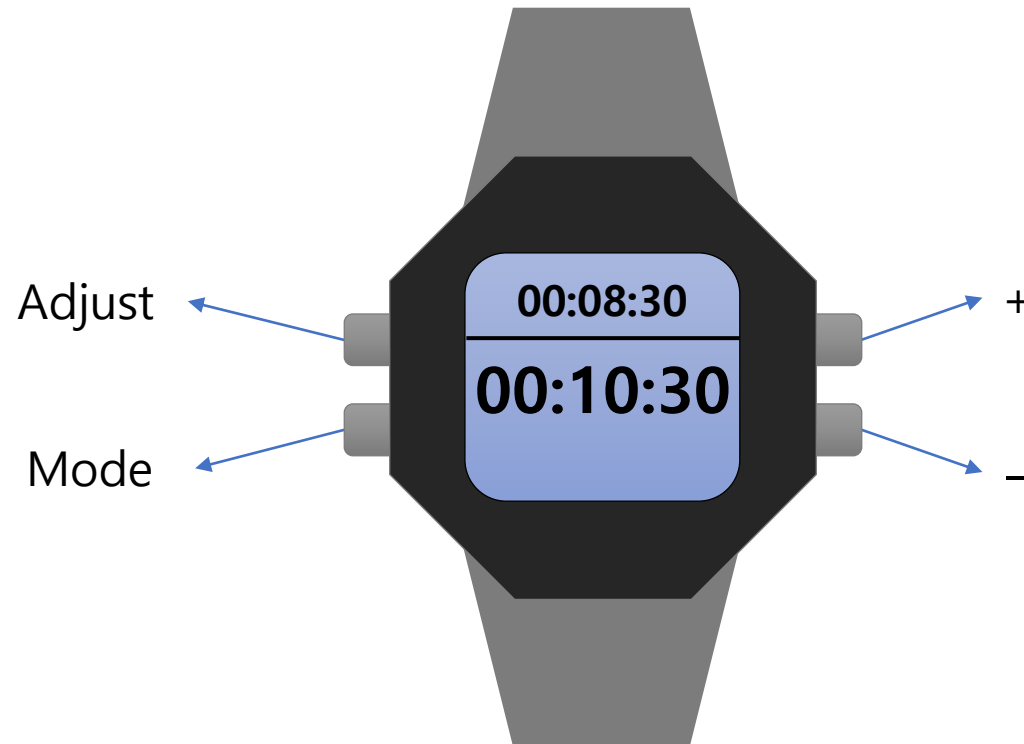

4. Time Keeping

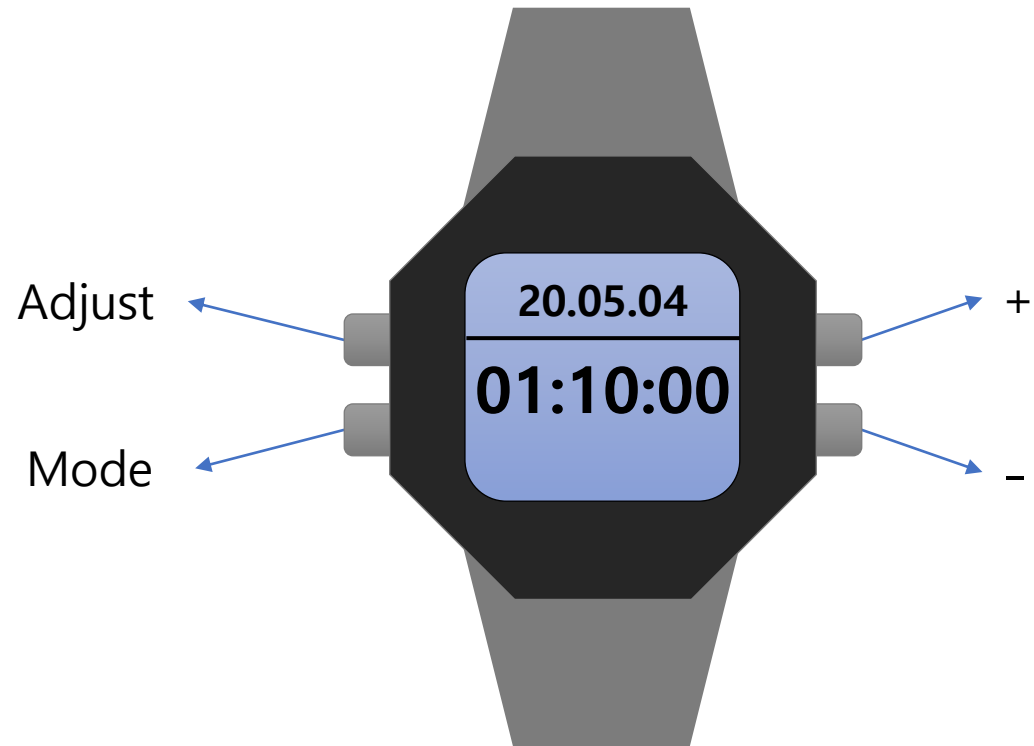

5. World Time



6. Lottery

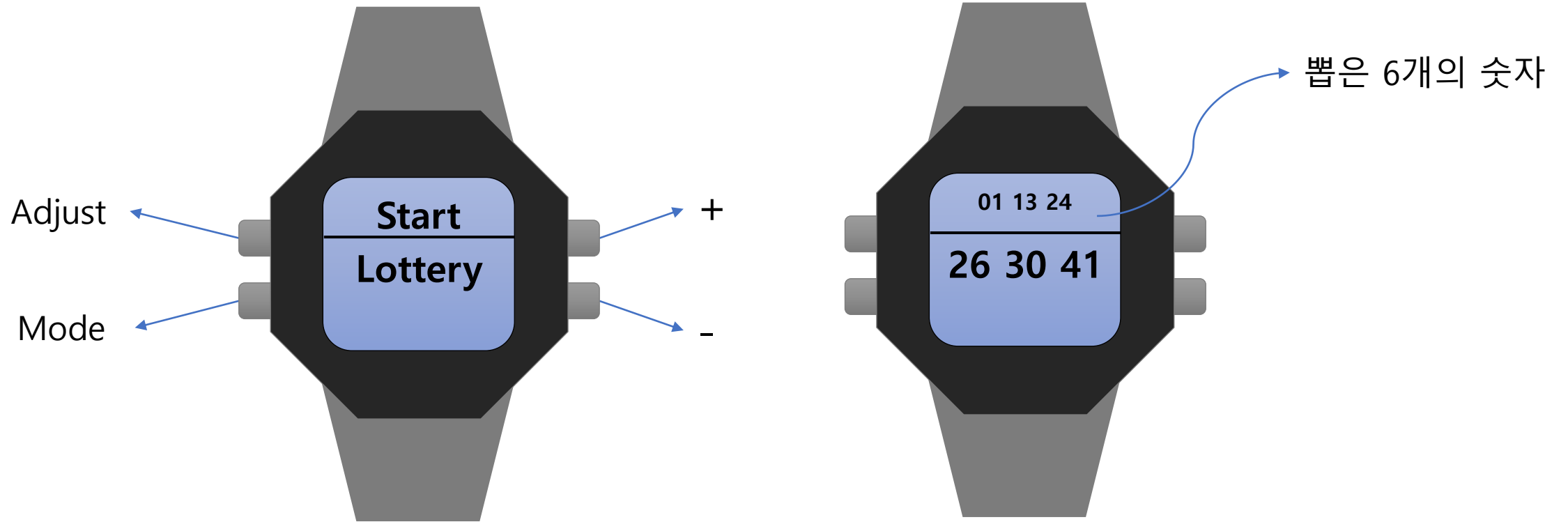

7. Mode Selection

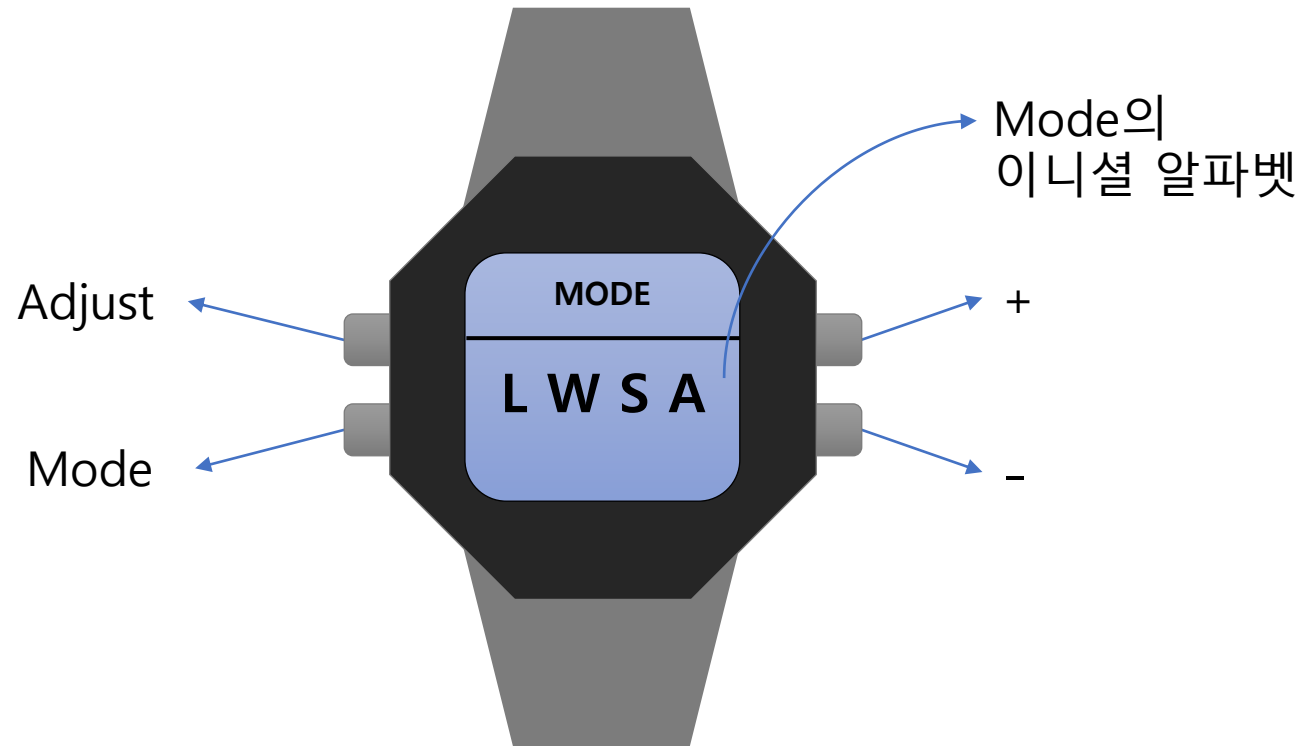

[2043] Define Interaction Diagrams

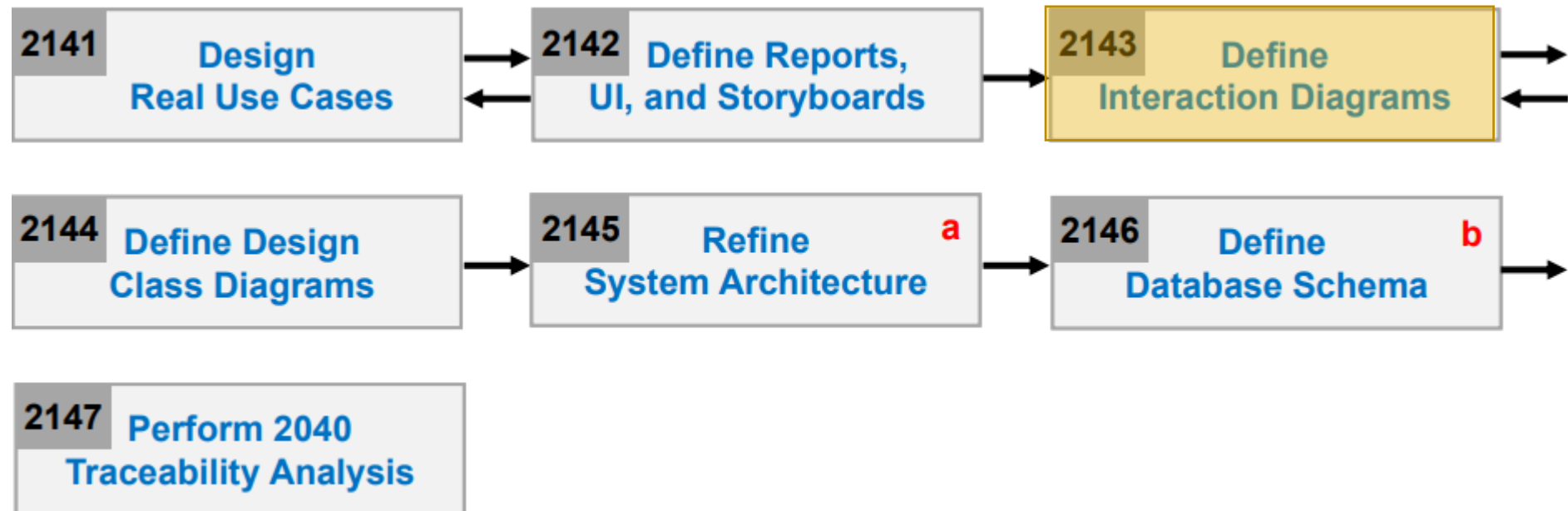

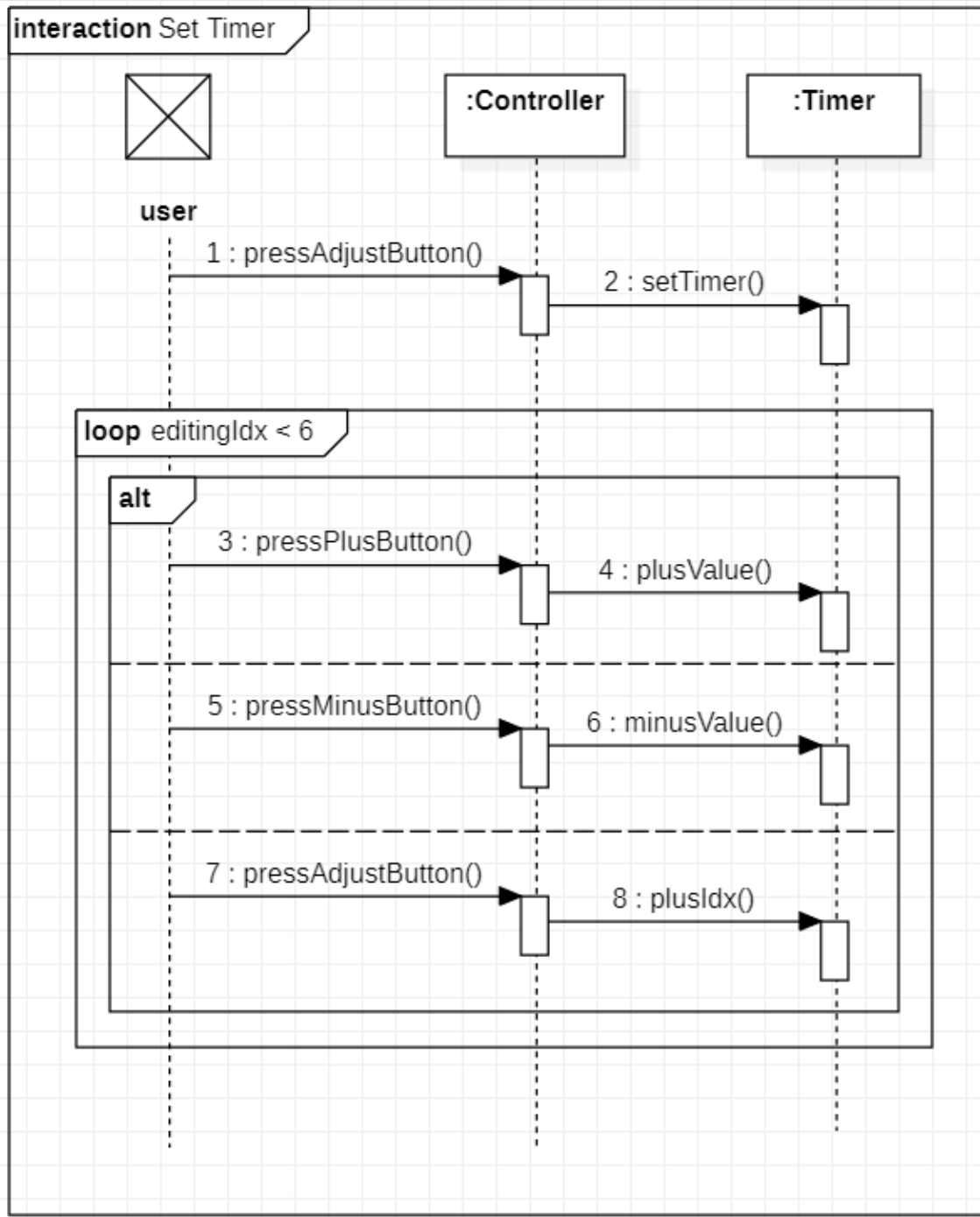

interaction Start Timer

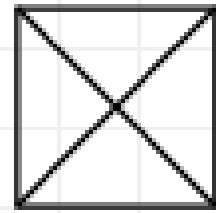

:Controller

:Timer

user

1 : pressPlusButton()

2 : startTimer()

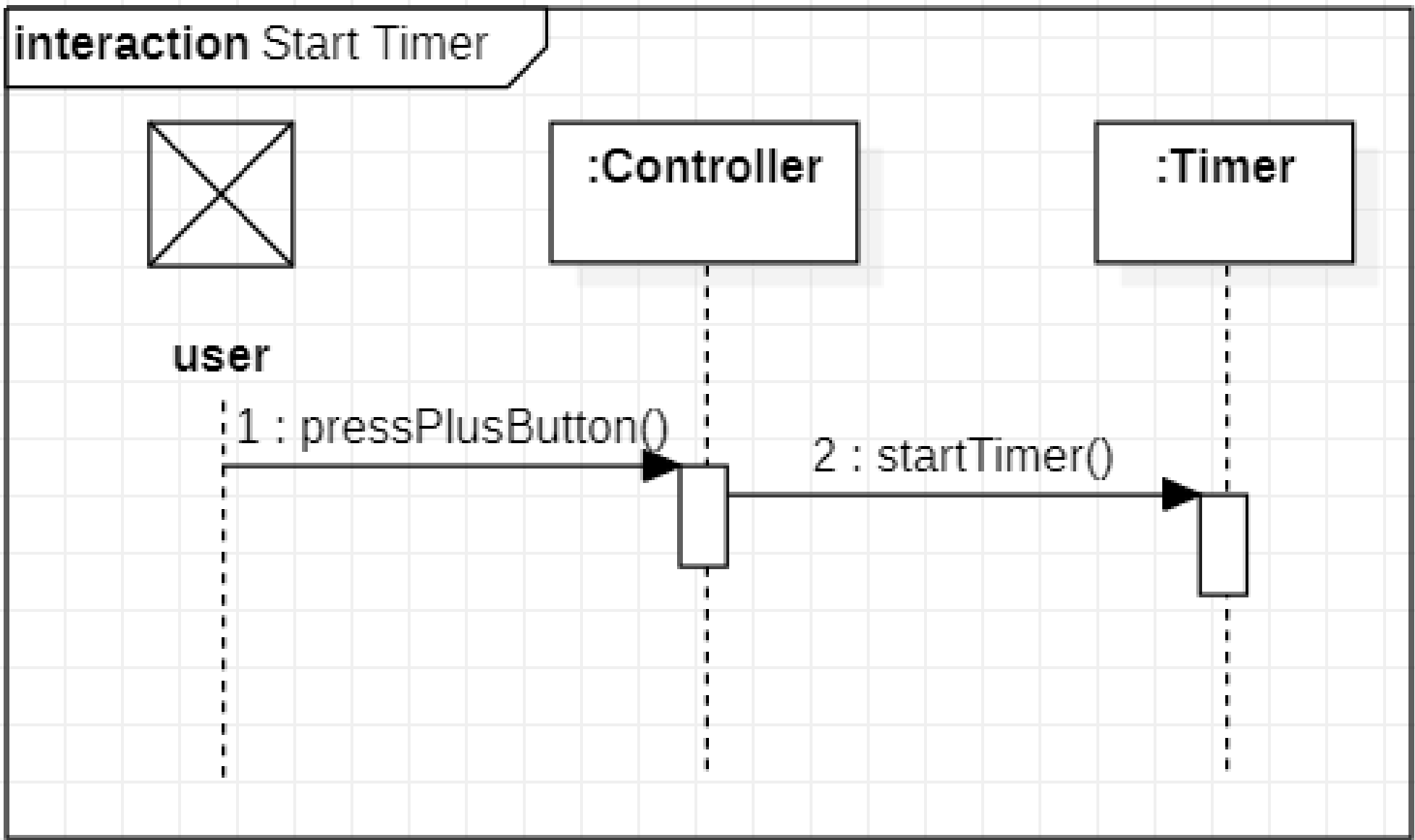

interaction Pause Timer

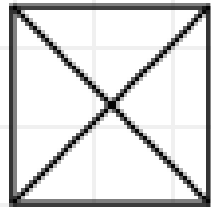

user

:Controller

:Timer

1 : pressPlusButton()

2 : pauseTimer()

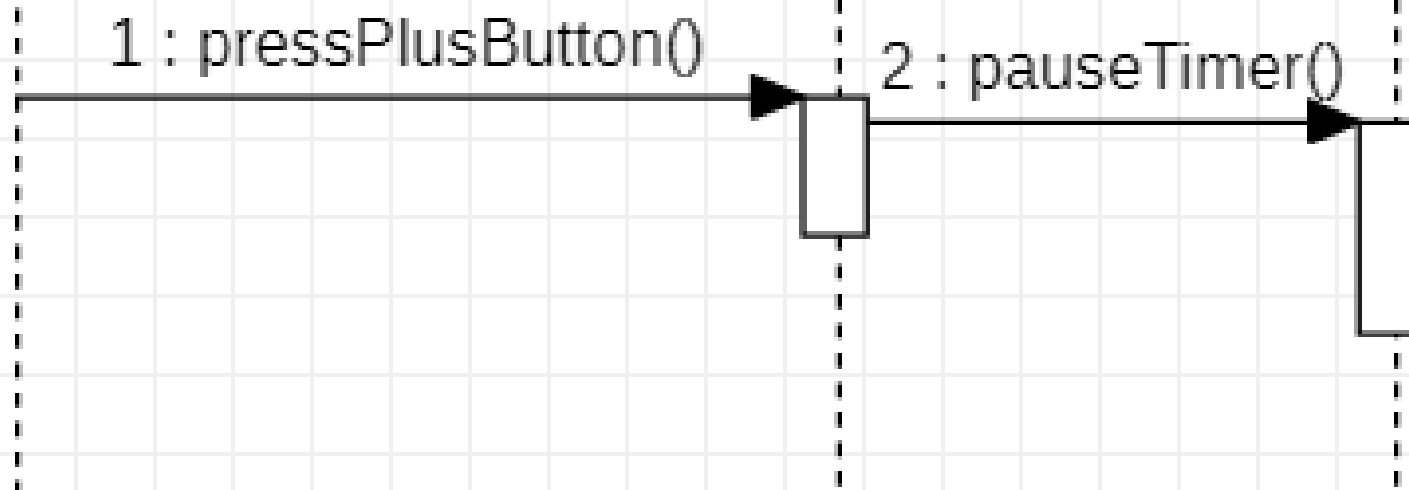

interaction Reset Timer

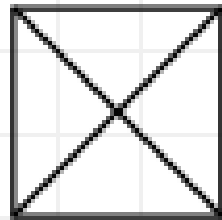

:Controller

:Timer

user

1 : pressMinusButton()

2 : resetTimer()

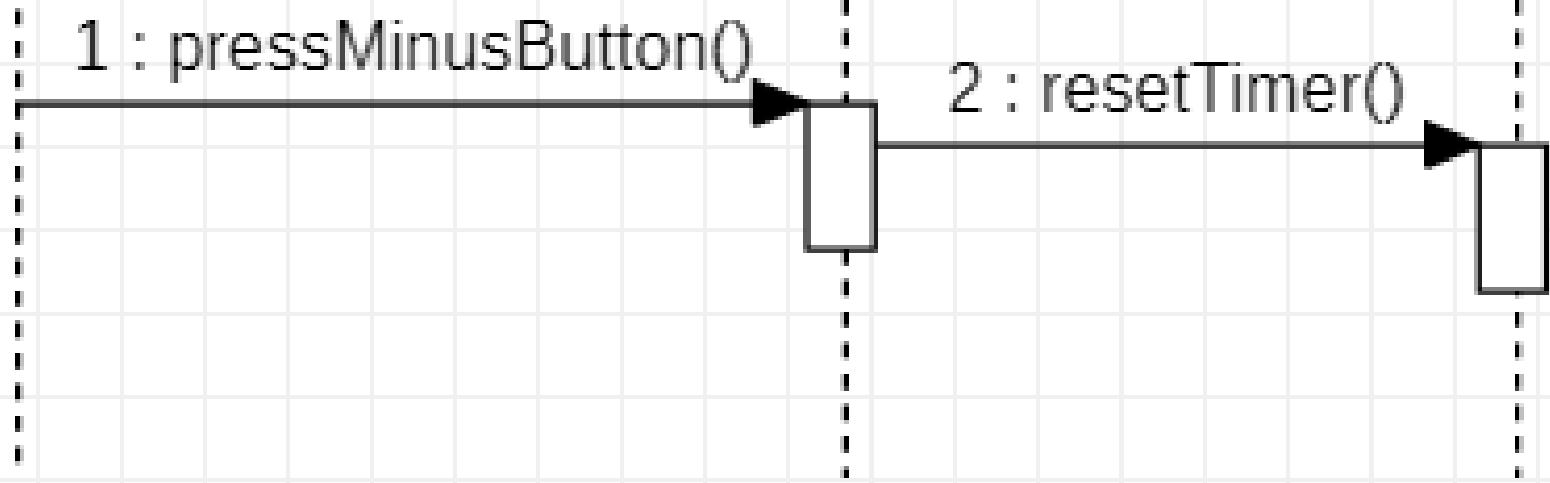

interaction Check Timer

:Timer



1 : checkTimer()

interaction Ring Timer

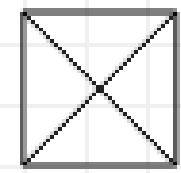

user

:Timer

GlobalSettings

:Buzzer

1 : getBuzzer()

2 : startBuzzer()

3 : ringBuzzer()

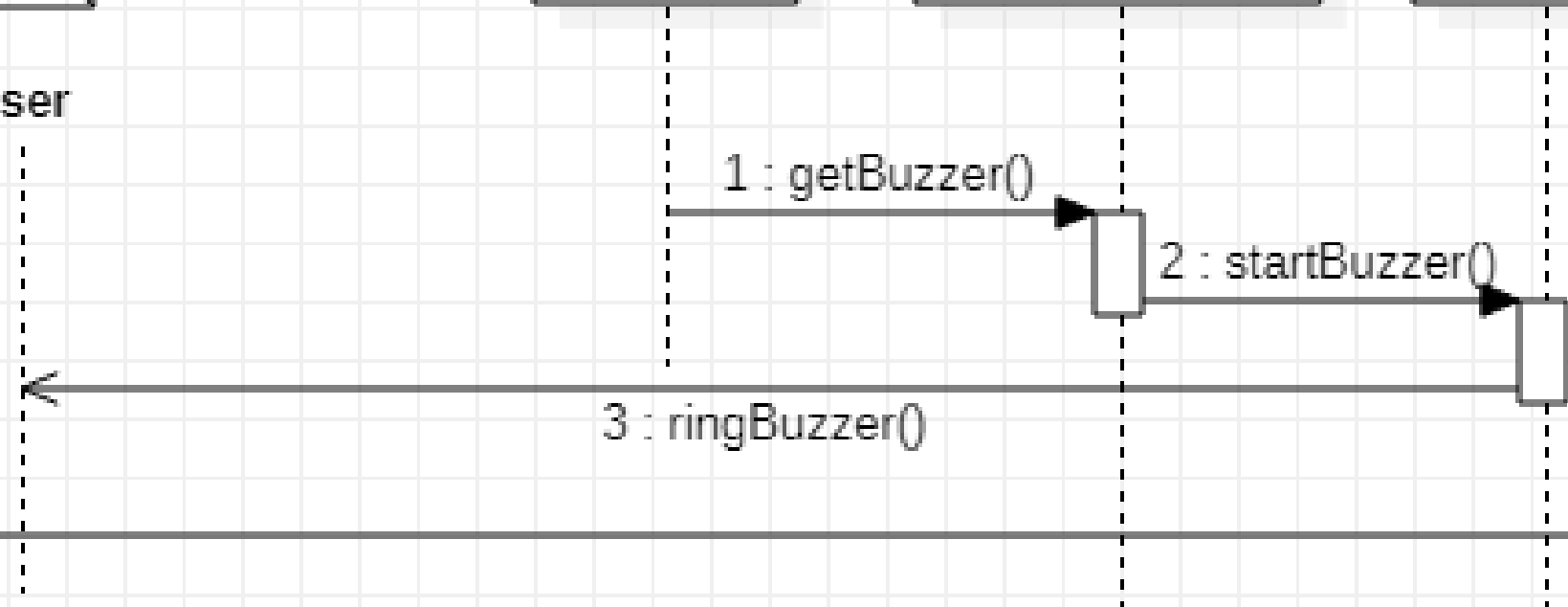

interaction Stop Ring Timer

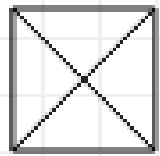

:Controller

:Timer

:GlobalSettings

:Buzzer

user

opt

[pressPlusButton() || pressMinusButton() || pressAdjustButton() || pressModeButton()]

1 : stopRingTimer()

2 : getBuzzer()

3 : stopBuzzer()

4 : stopRingBuzzer()

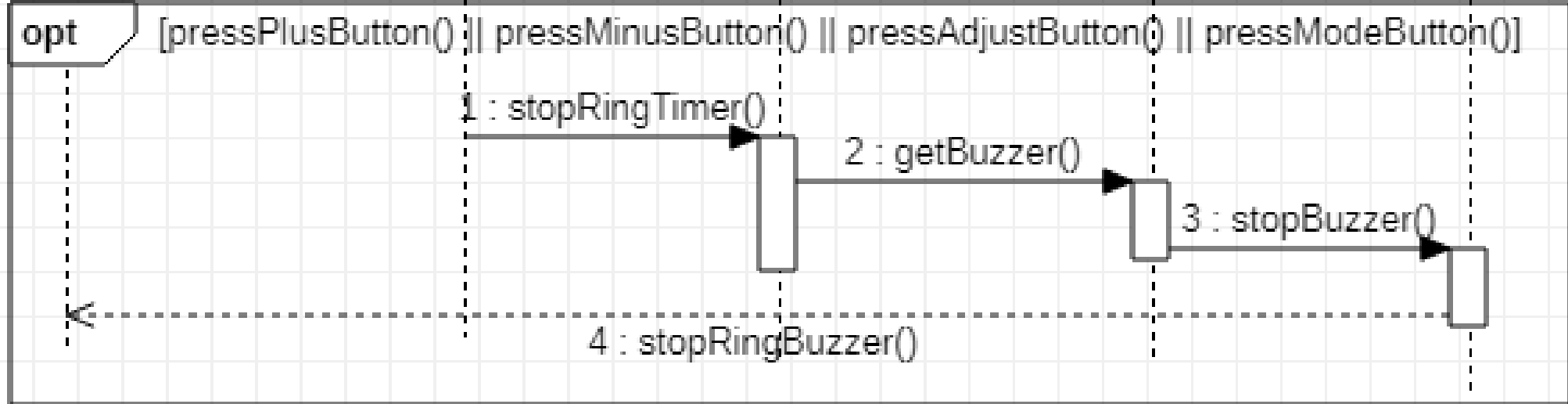

interaction Show Timer

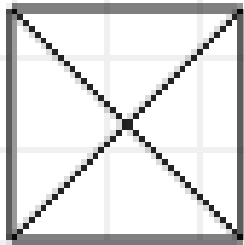

user



:Timer

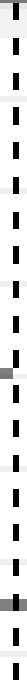

1 : processOnScreen()

interaction Set Alarm

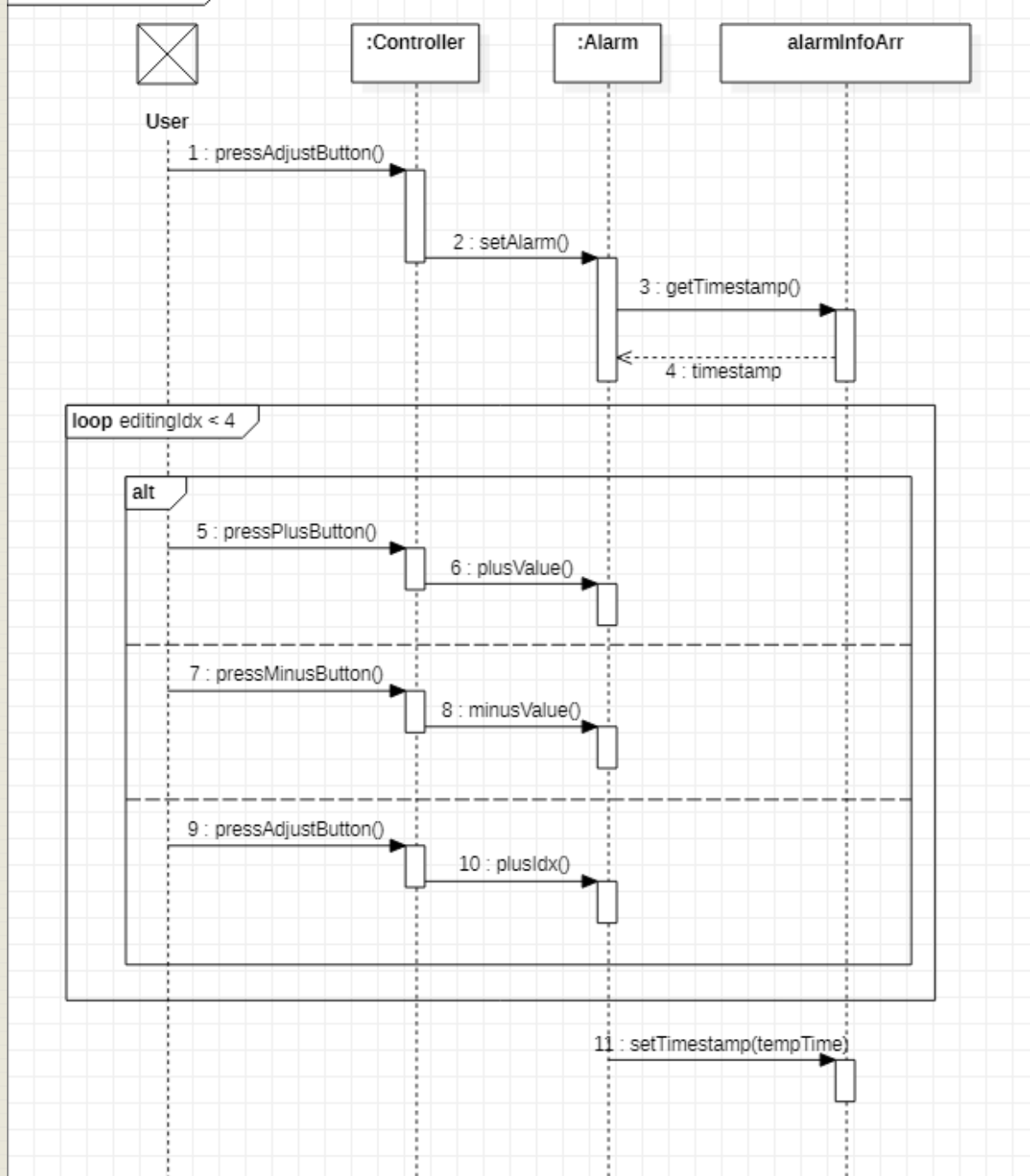

interaction On Alarm

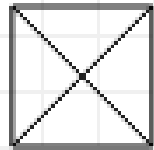

User

:Controller

:Alarm

alarmInfoArr : AlarmInfo

1 : pressMinusButton()

2 : onAlarm()

3 : setIsOn(true)

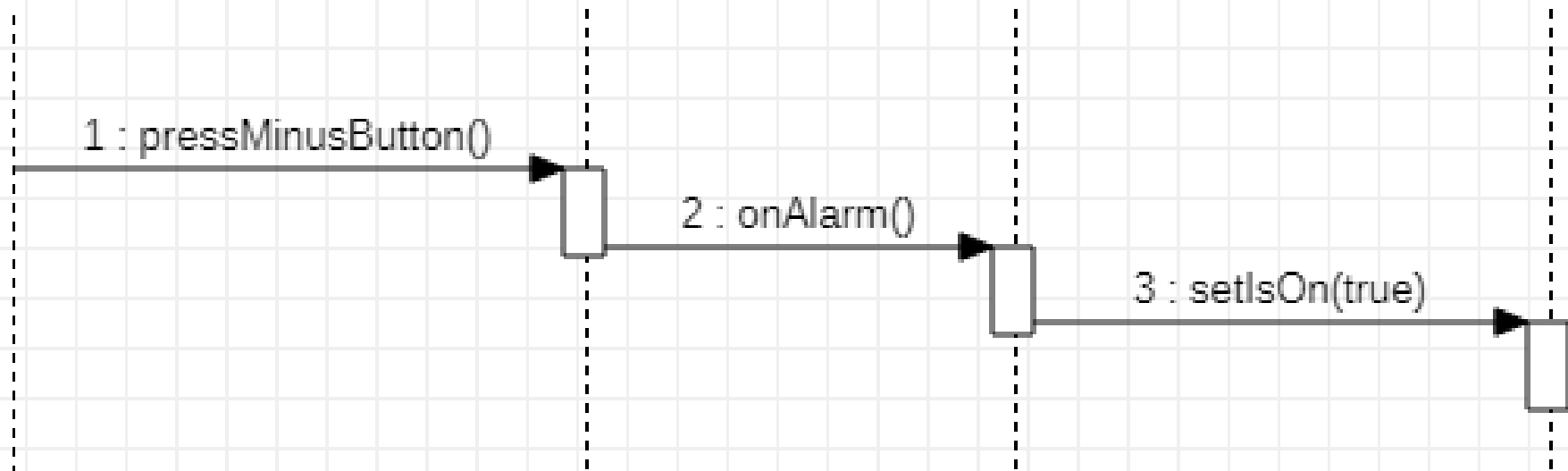

interaction Off Alarm

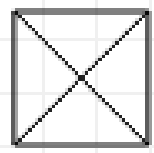

User

:Controller

:Alarm

alarmInfoArr : AlarmInfo

1 : pressMinusButton()

2 : offAlarm()

3 : setIsOn(false)



interaction Next Alarm

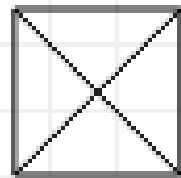

User

:Controller

:Alarm

1 : pressPlusButton()

2 : nextAlarm()

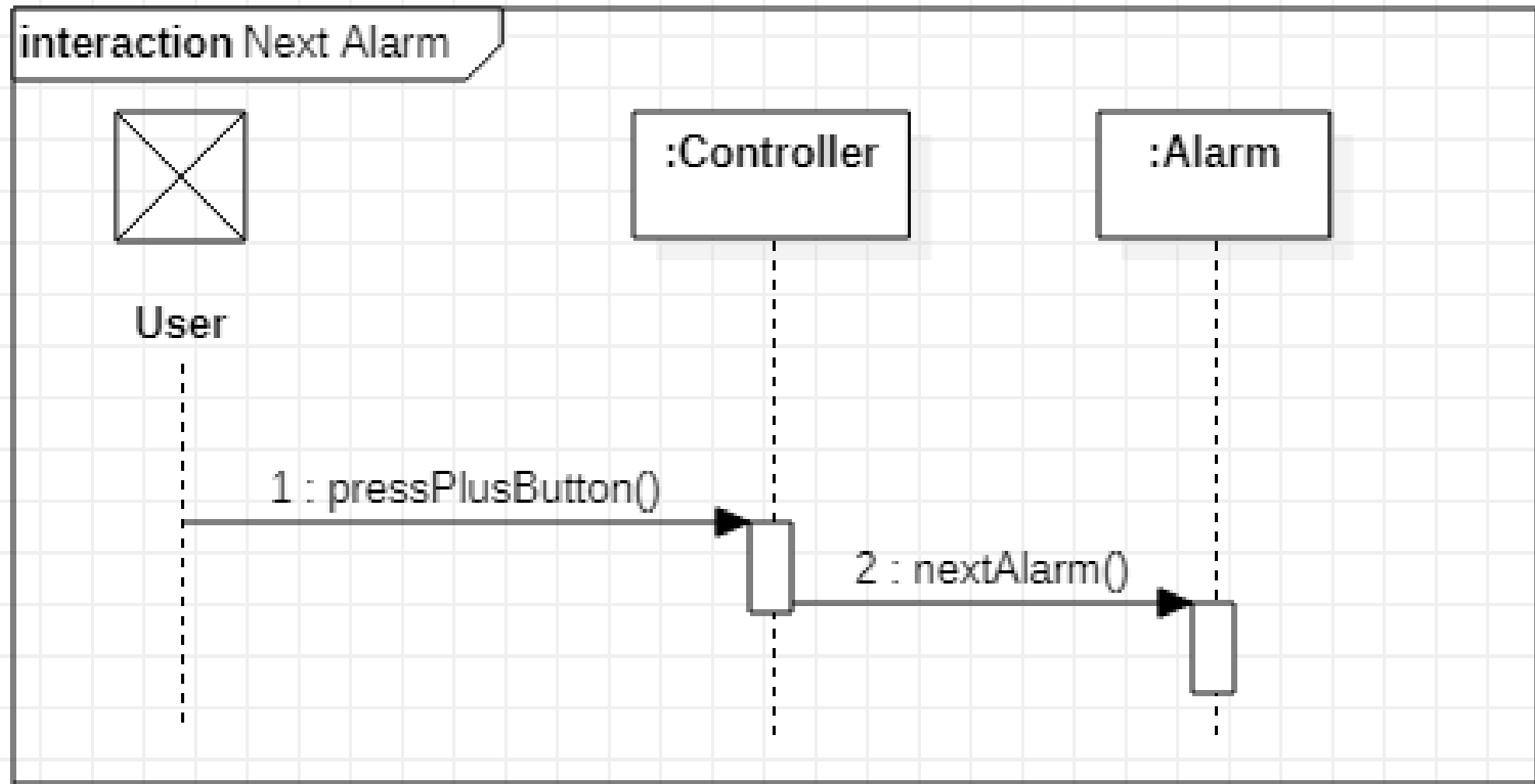

interaction Check Alarm

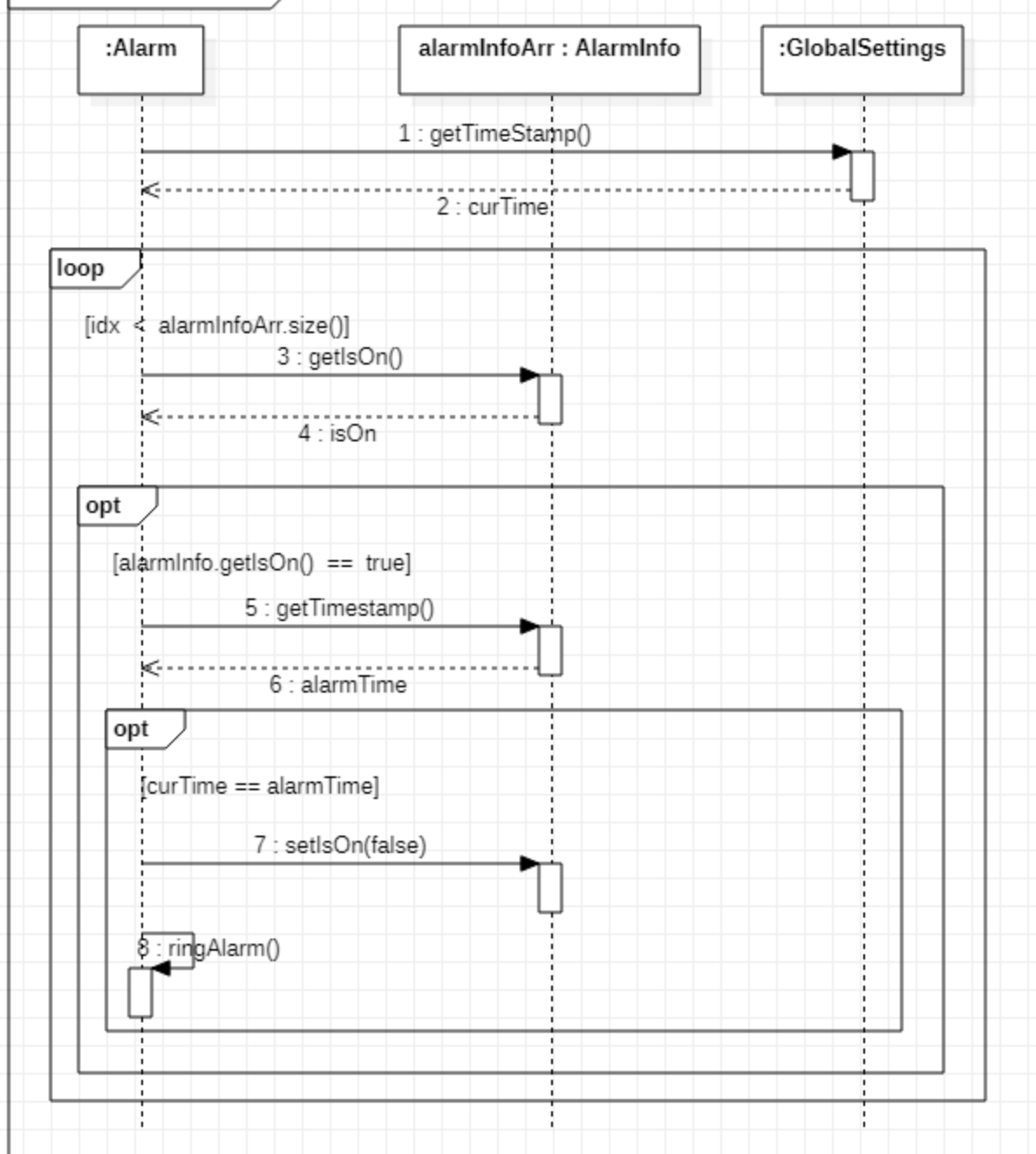

interaction Ring Alarm

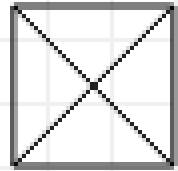

User

:Alarm

GlobalSettings

Buzzer

1 : getBuzzer()

2 : startBuzzer()

3 : ringBuzzer()

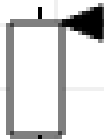

interaction Stop Ring Alarm

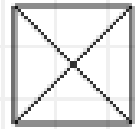

User

:Controller

:Alarm

GlobalSettings

Buzzer

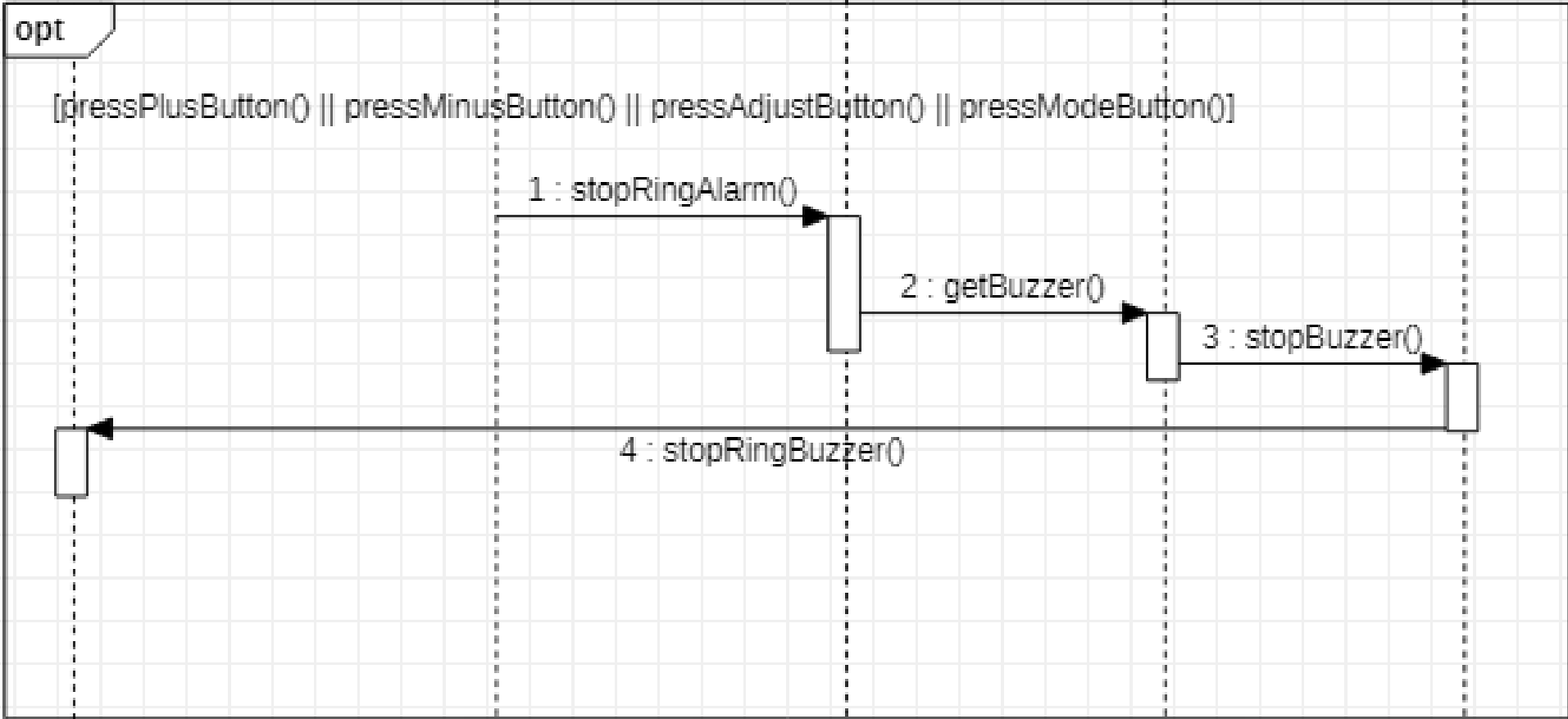

interaction Show Alarm

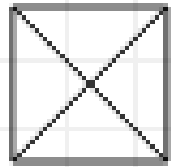

User

:Alarm

alarmInfoArr : AlarmInfo

1 : getTimestamp()

2 : timestamp

3 : getIsOn()

4 : isOn

5 : processOnScreen()

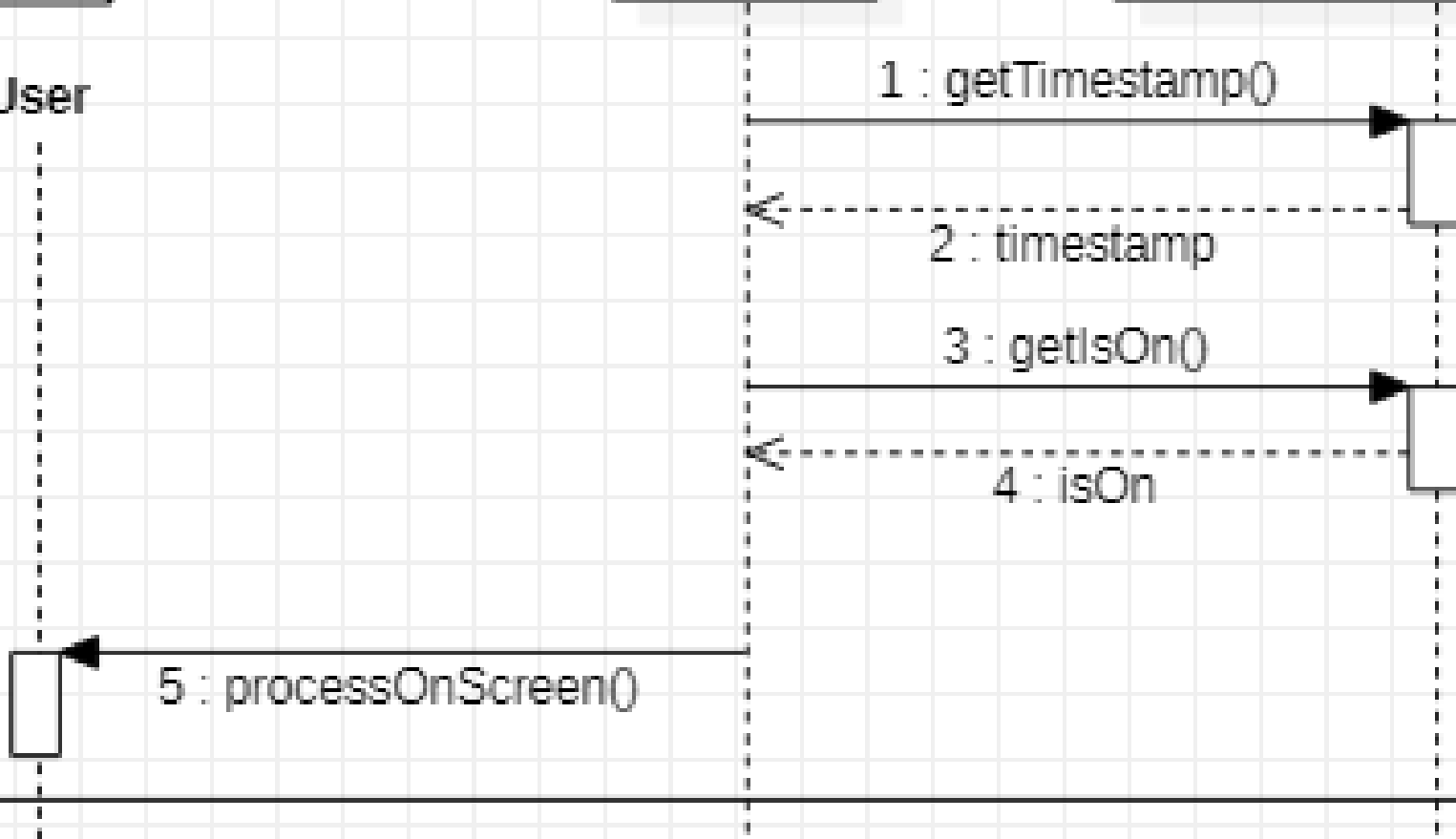

interaction Start Stopwatch

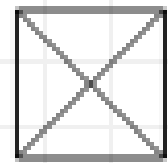

User

:Controller

:Stopwatch

1 : pressPlusButton()

2 : startStopwatch()

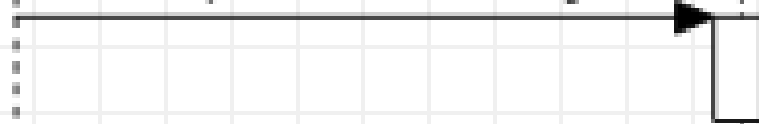

interaction Pause Stopwatch

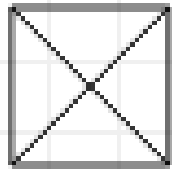

User

:Controller

:Stopwatch

1 : pressPlusButton()

2 : pauseStopwatch()

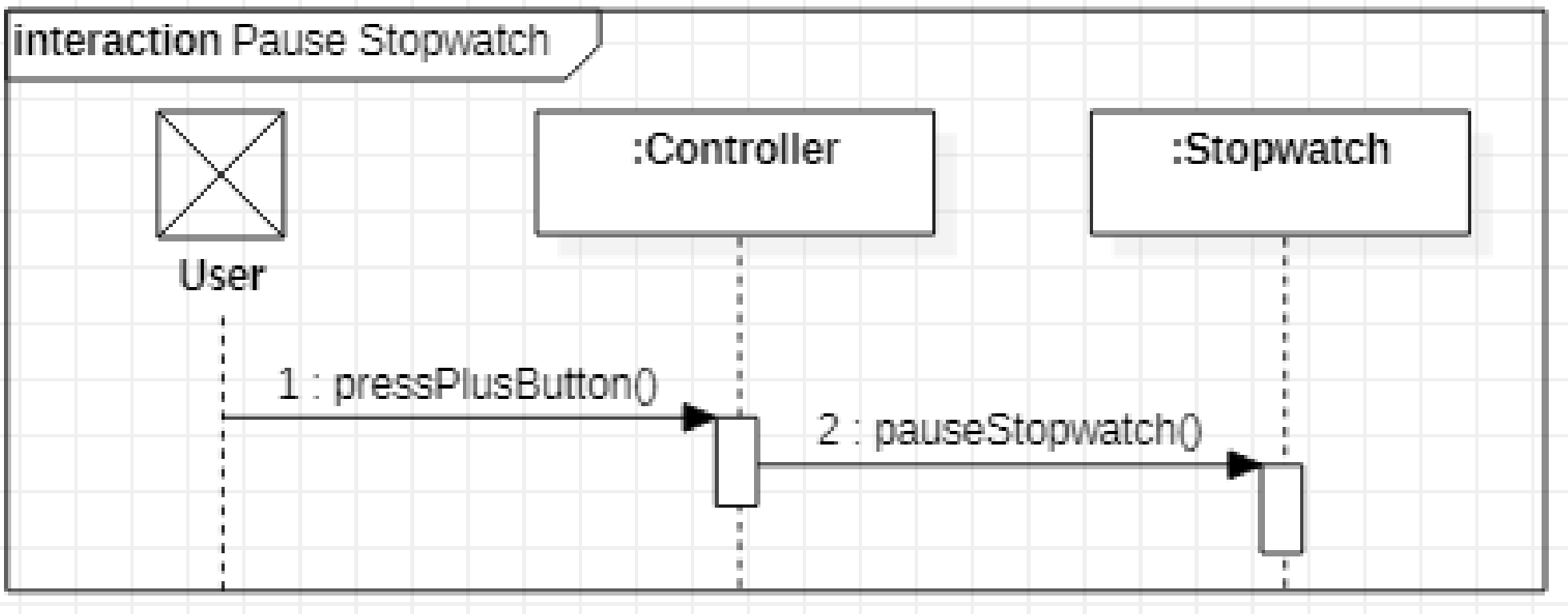

interaction Reset Stopwatch

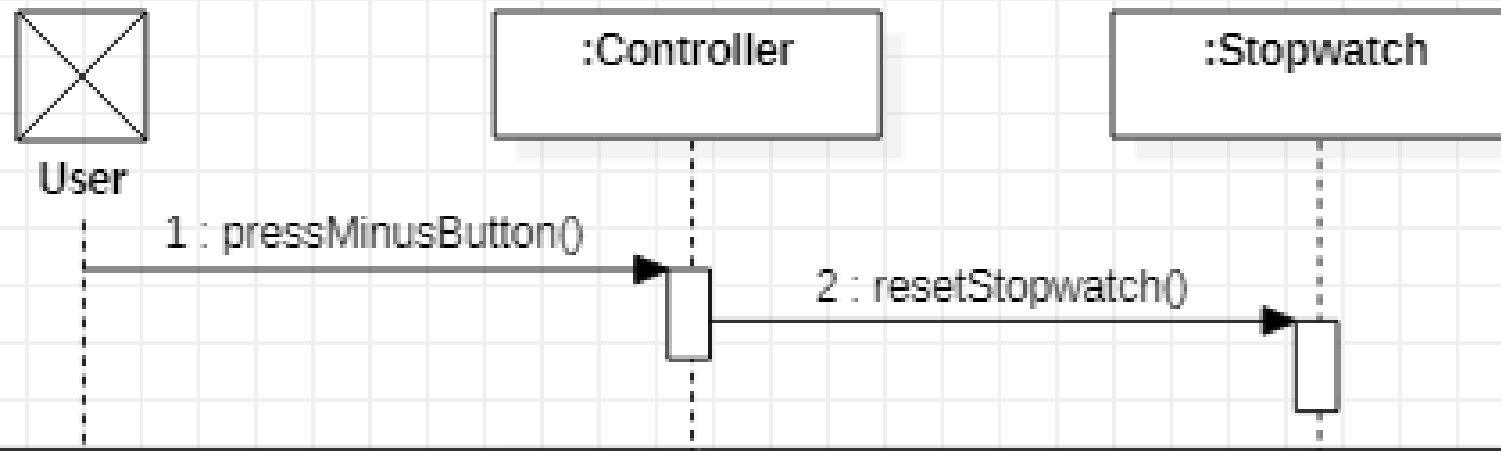

interaction Record Lab

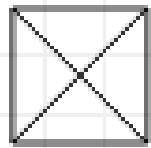

User

:Controller

:Stopwatch

1 : pressAdjustButton()

2 : recordLap()

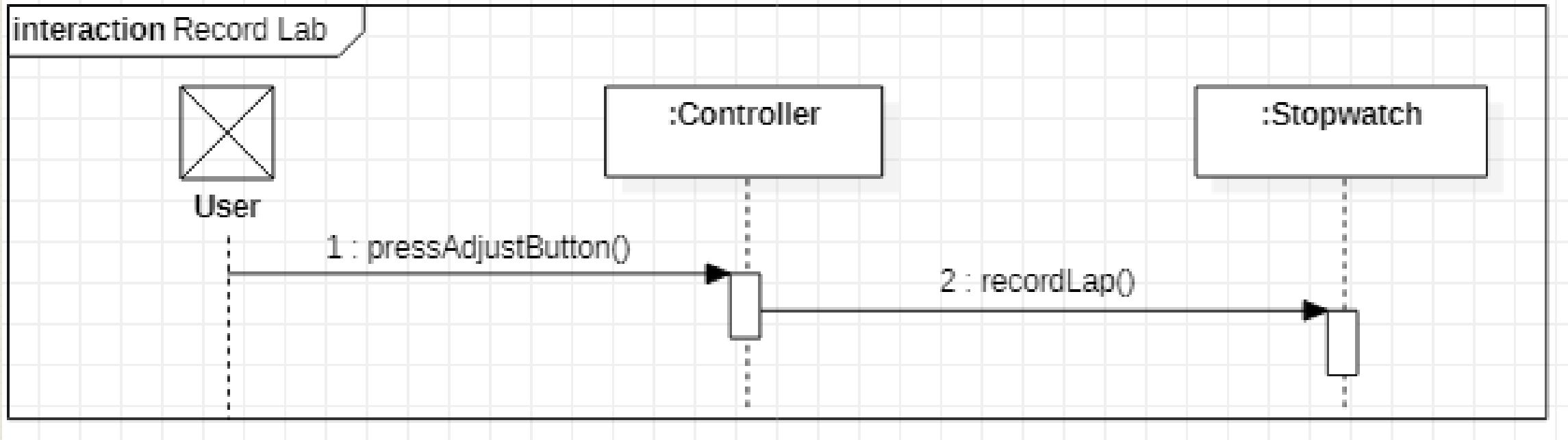

interaction Run Stopwatch

:Stopwatch

1 : processBackground()



interaction Show Stopwatch

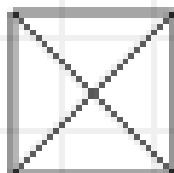

User



:Stopwatch



1 : processOnScreen()

interaction Timezone to Right

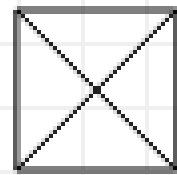

User

: Controller

: WorldTime

1 : pressPlusButton()

2 : timezoneToRight()

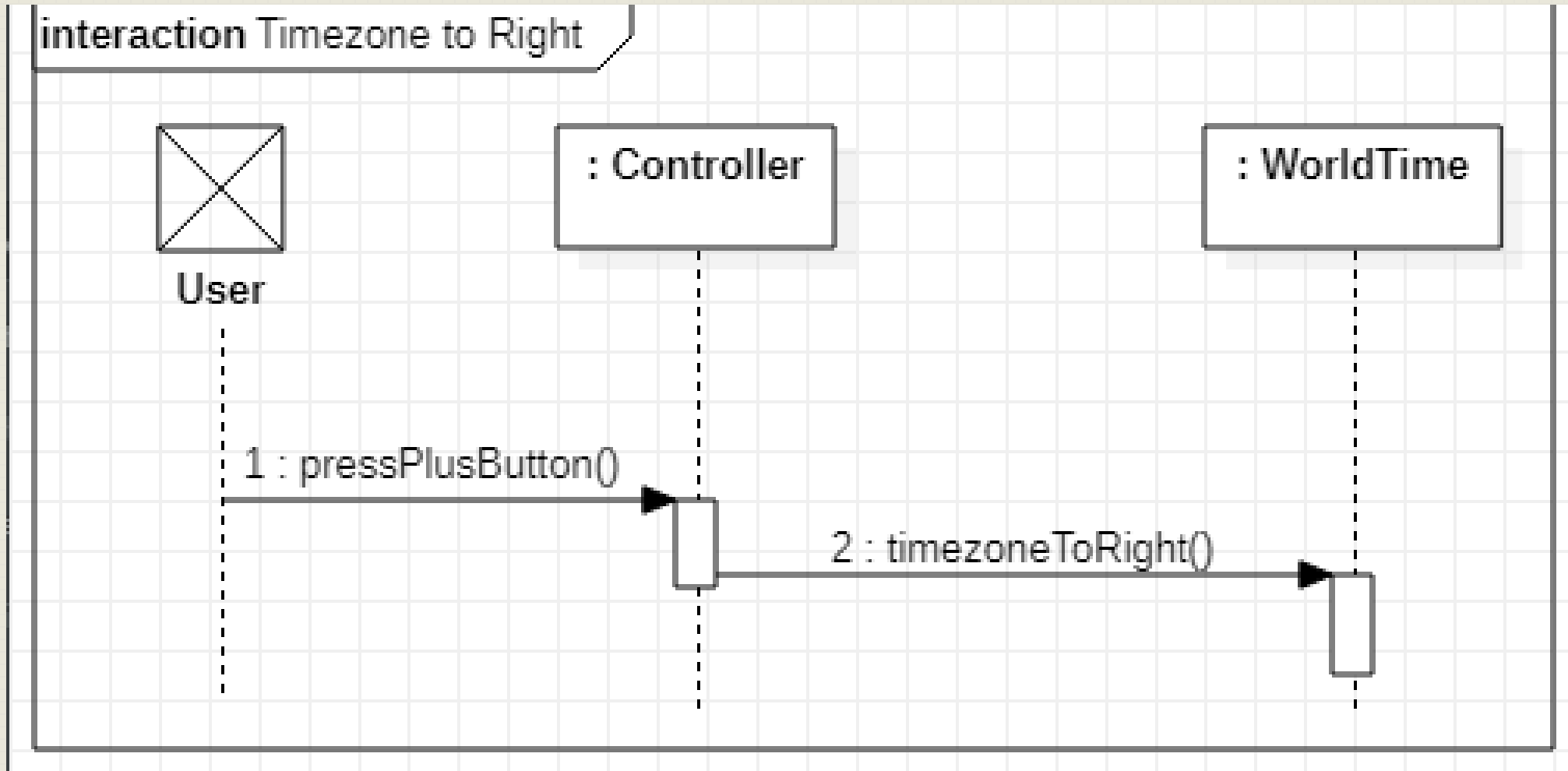

interaction Timezone to Left

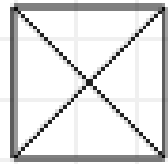

User



: Controller



: WorldTime

1 : pressMinusButton()

2 : timezoneToLeft()

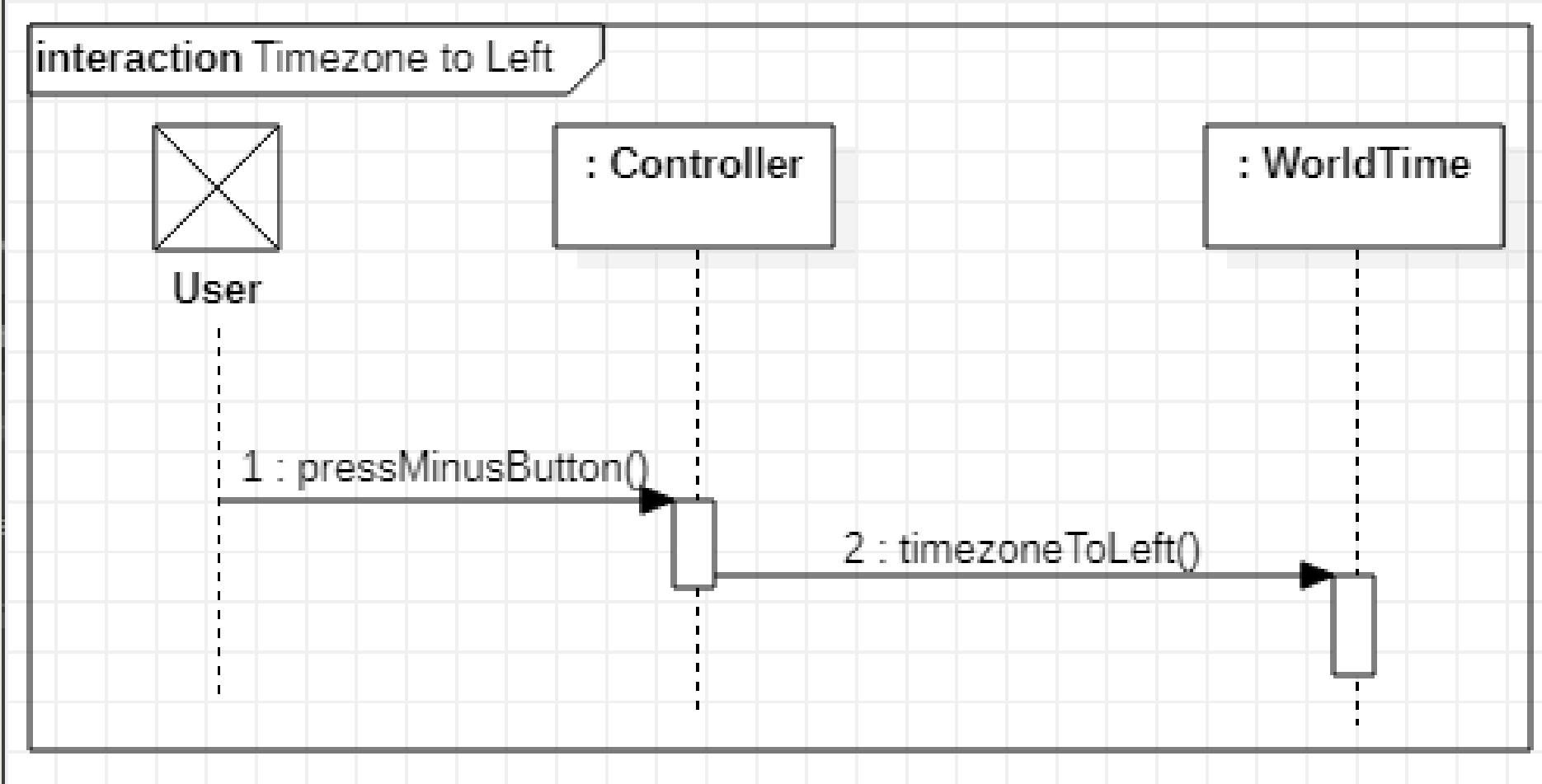

interaction Show WorldTime

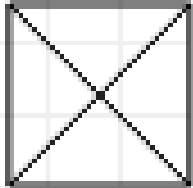

User



: WorldTime



1 : processOnScreen()

interaction Set Timekeeping

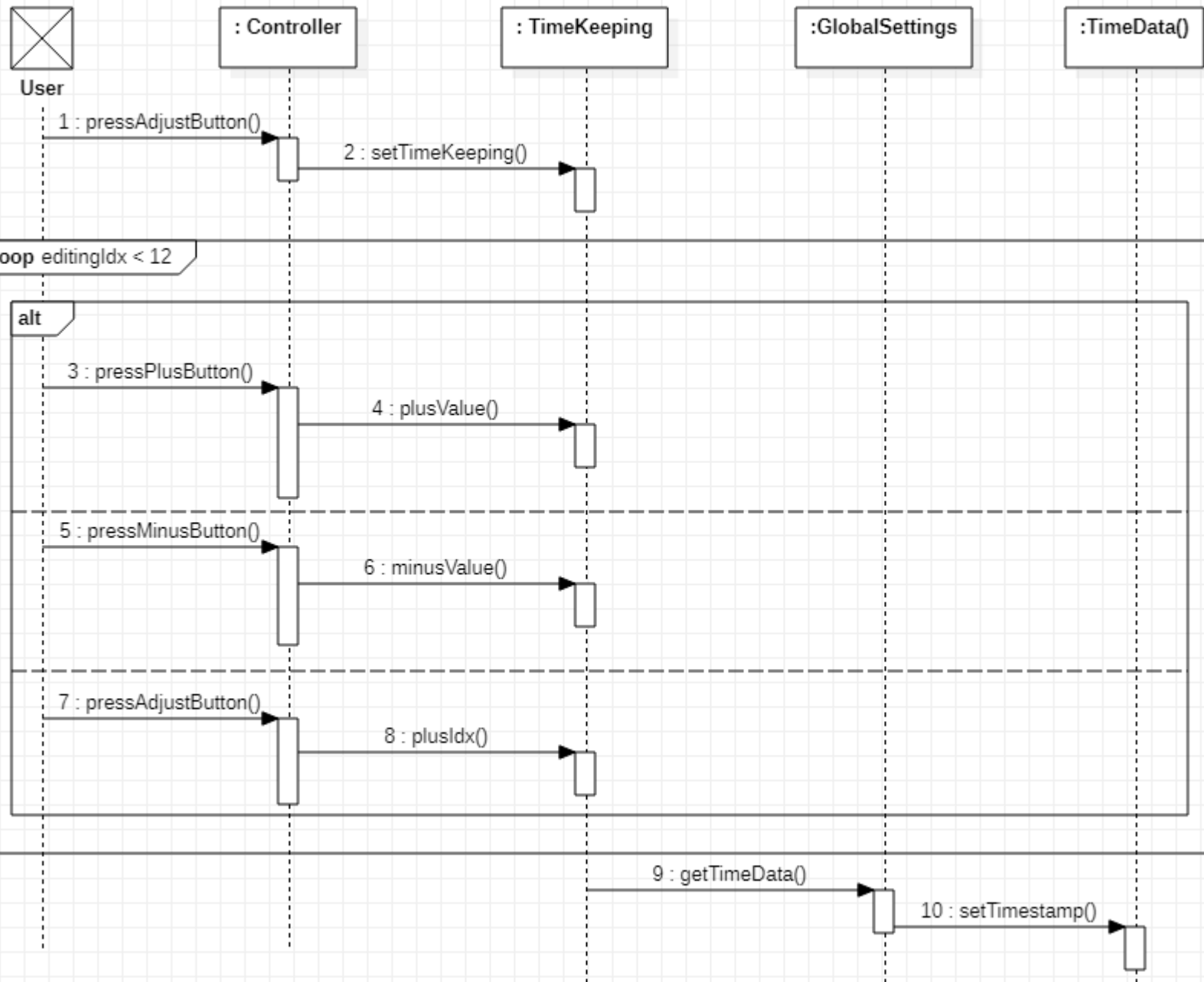

interaction Show Timekeeping

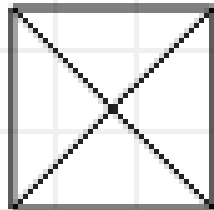

User

: TimeKeeping

1 : processOnScreen()

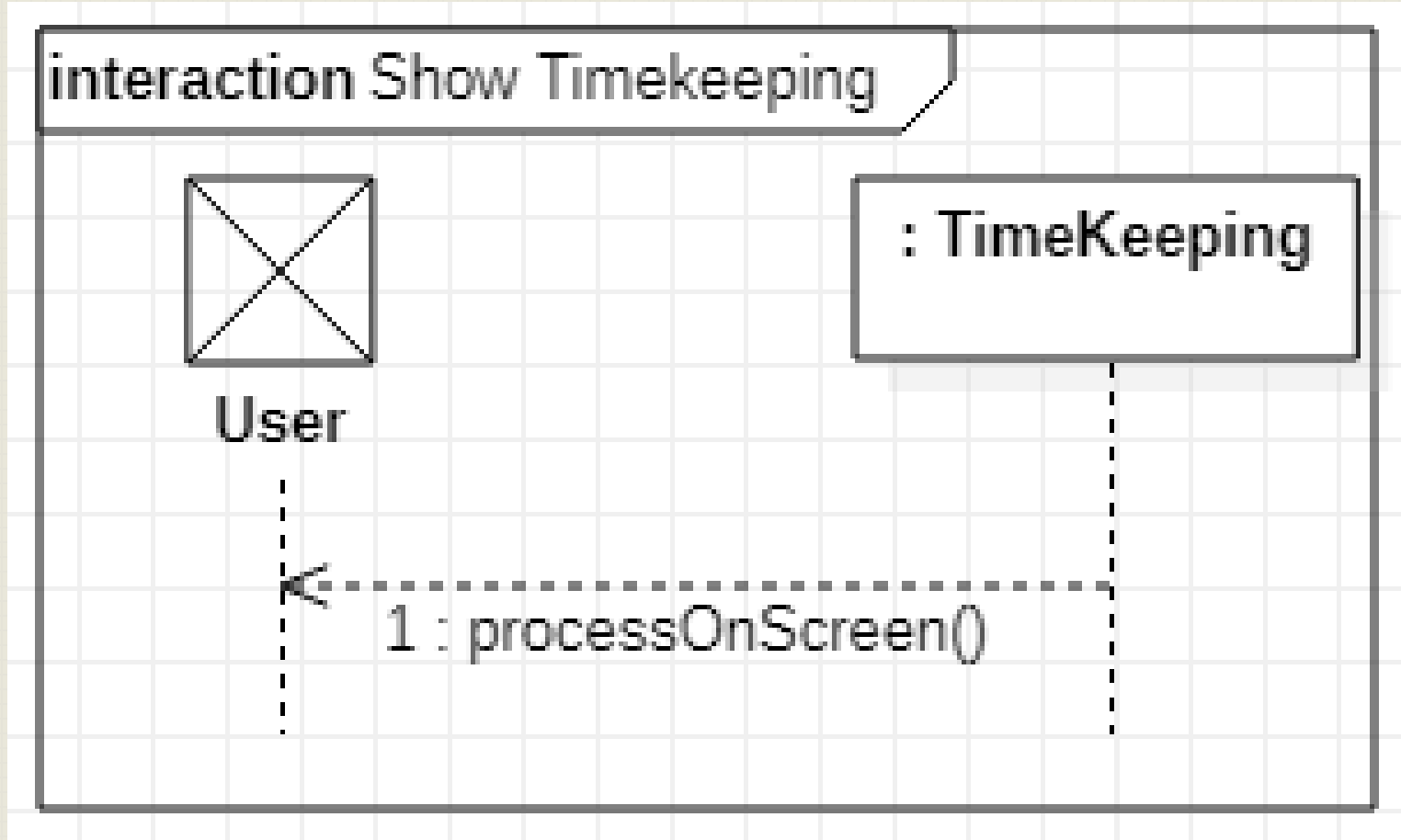

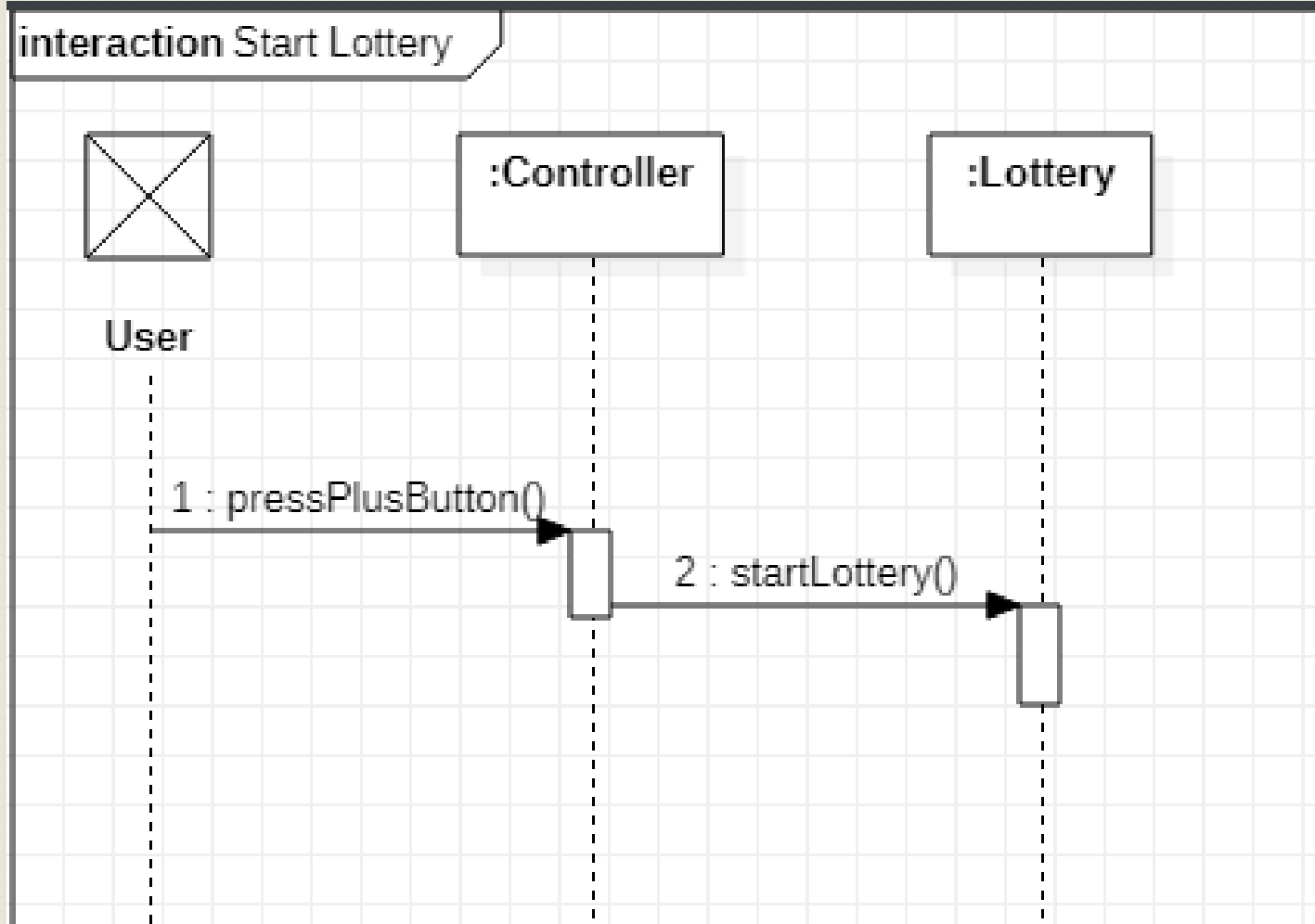

interaction Reset Lottery

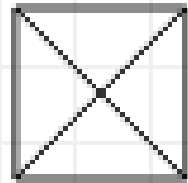

User

:Controller

:Lottery

1 : pressMinusButton()

2 : resetLottery()

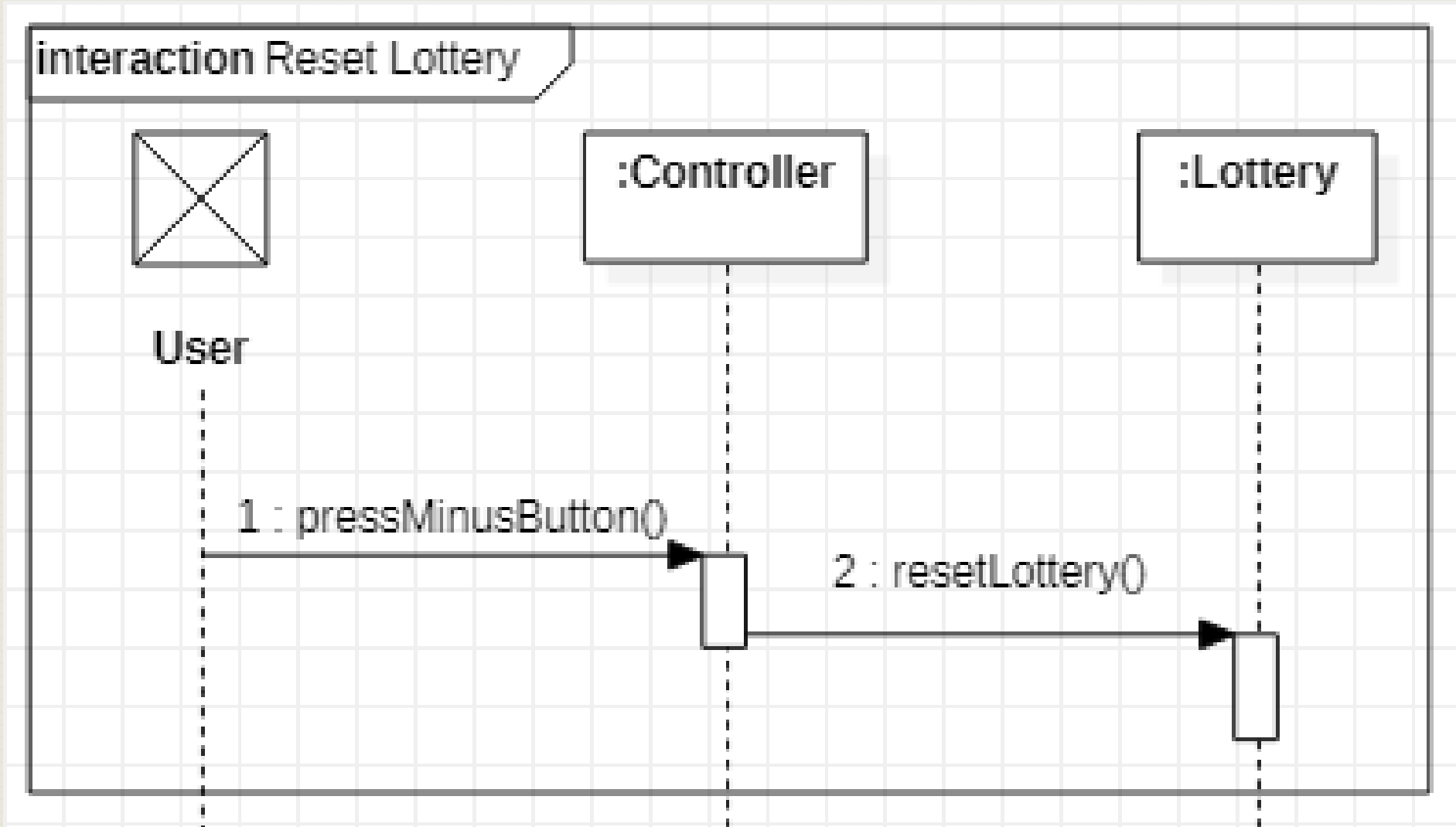

interaction Show Lottery

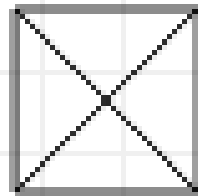

User

:Lottery

1 : processOnScreen()

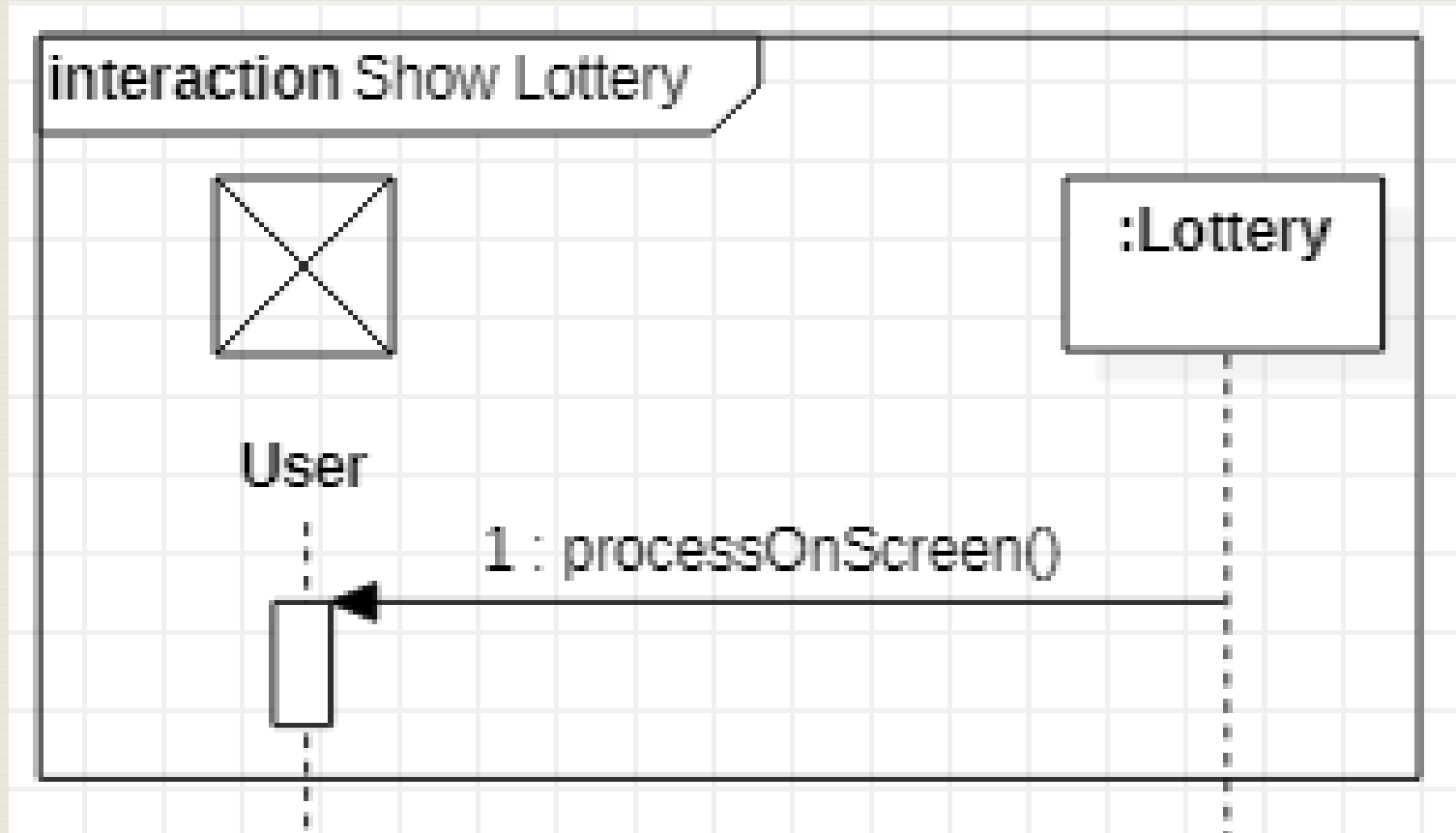
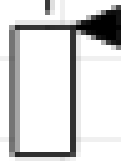

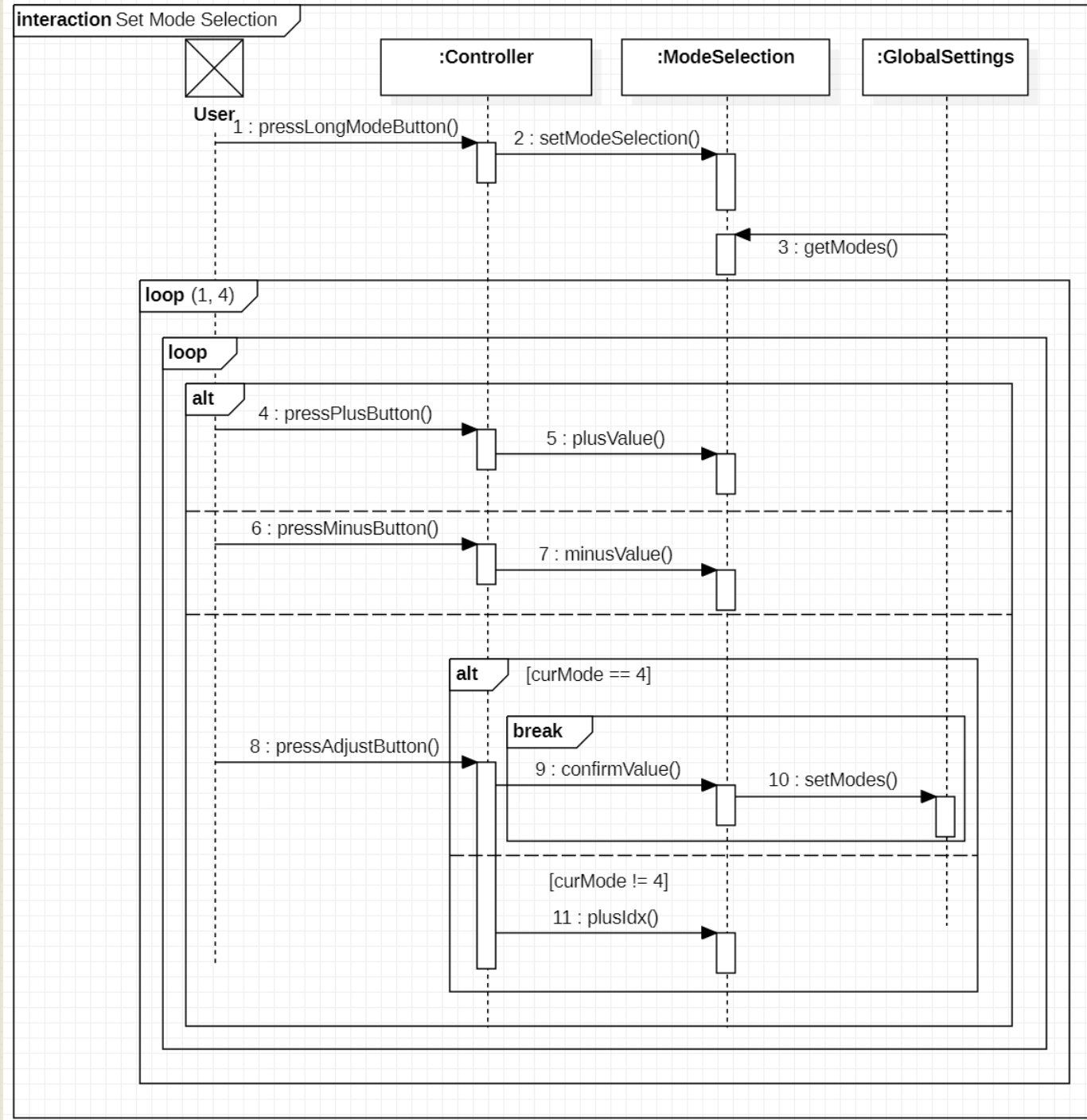

interaction Show Mode Selection

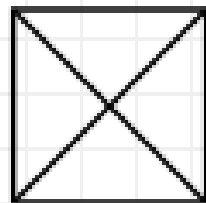

User



:ModeSelection

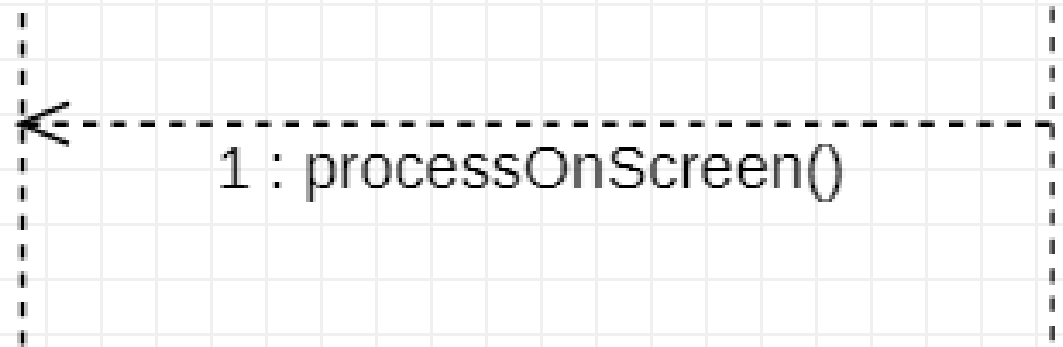

1 : processOnScreen()

interaction Change Mode

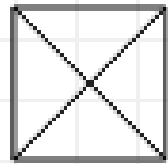

user

:Controller

:GlobalSettings

1 : pressModeButton()

2 : changeMode()

3 : getCurMode()

4 : setCurMode()

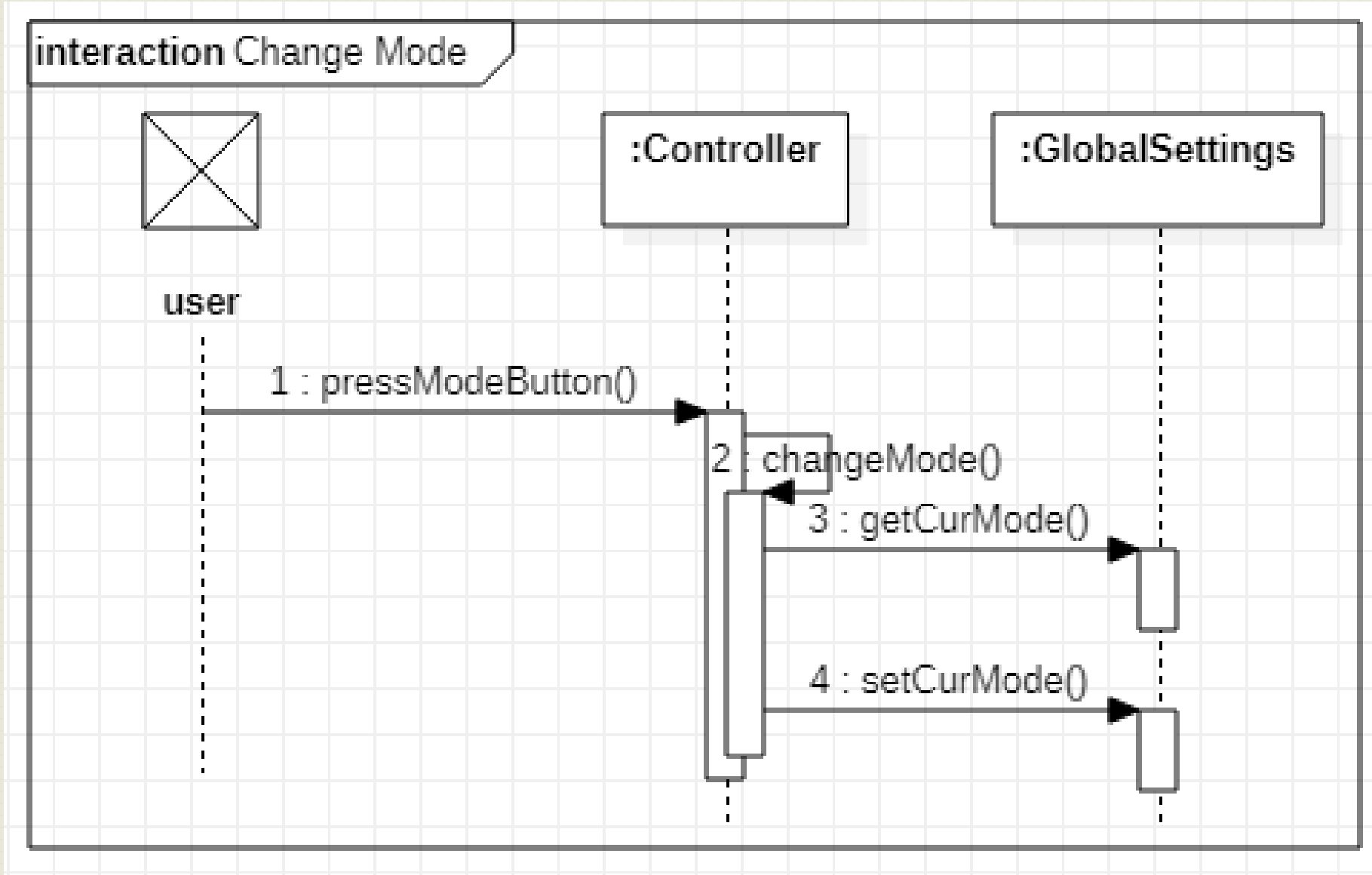

interaction Time Checkout

:TimeTicker

:Controller

:GlobalSettings

:TimeData

1 : timeCheckOut()

2 : setCurMode()

3 : getTimeData()

4 : setNoActionTime(0)

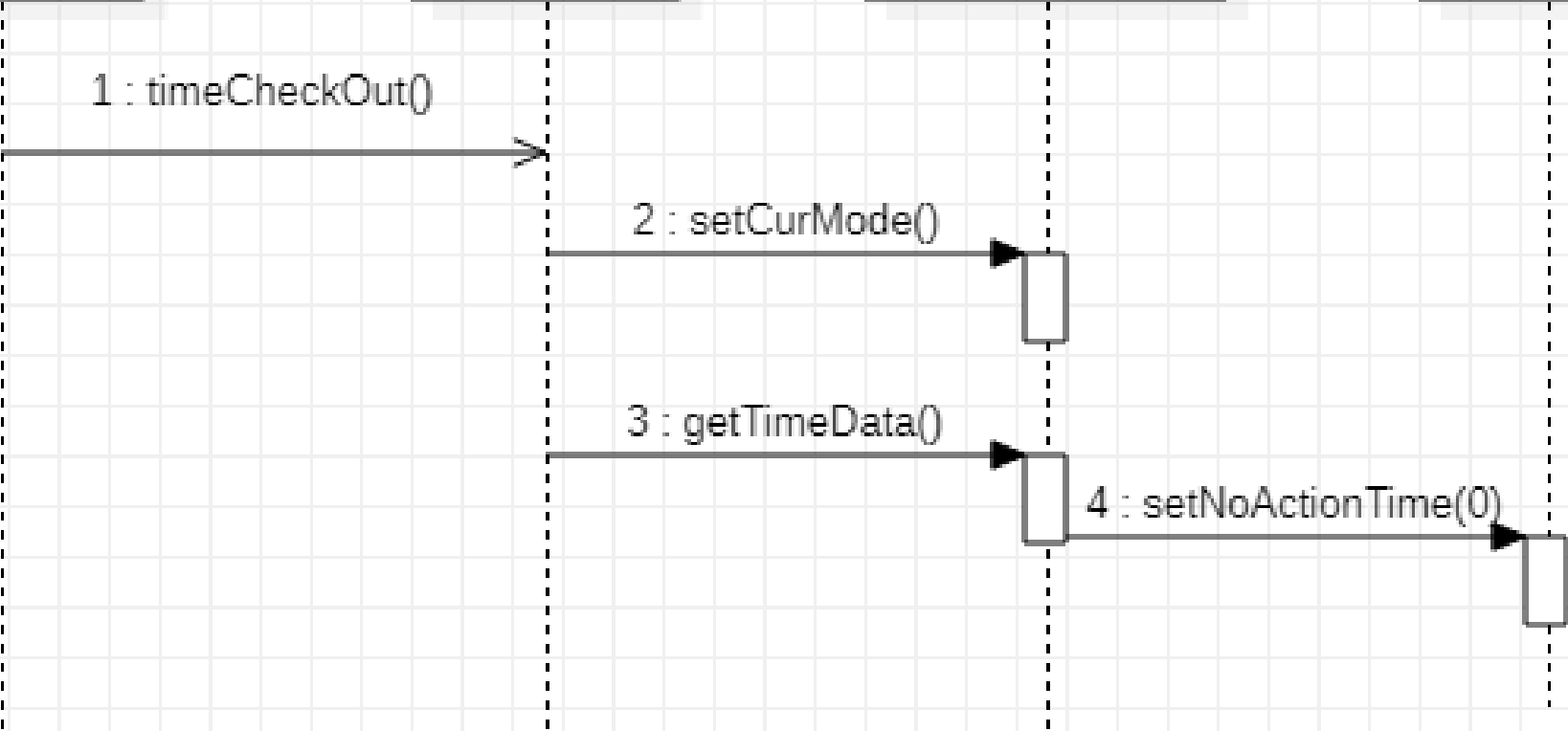

[2044] Define Design Class Diagrams

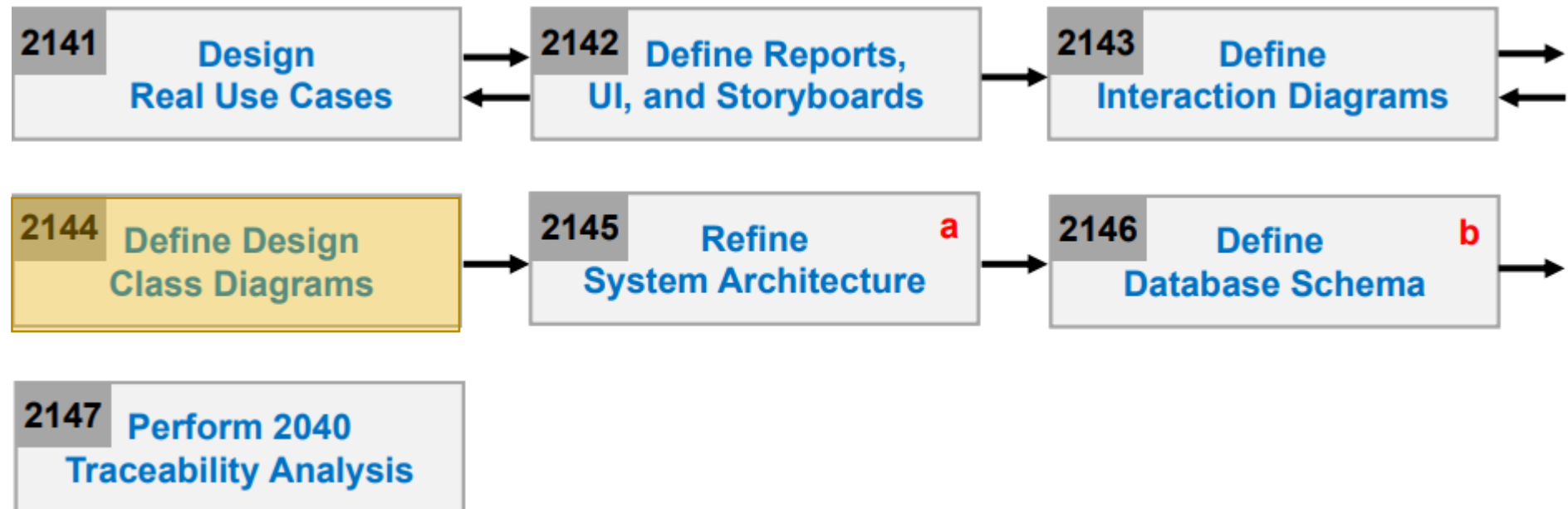

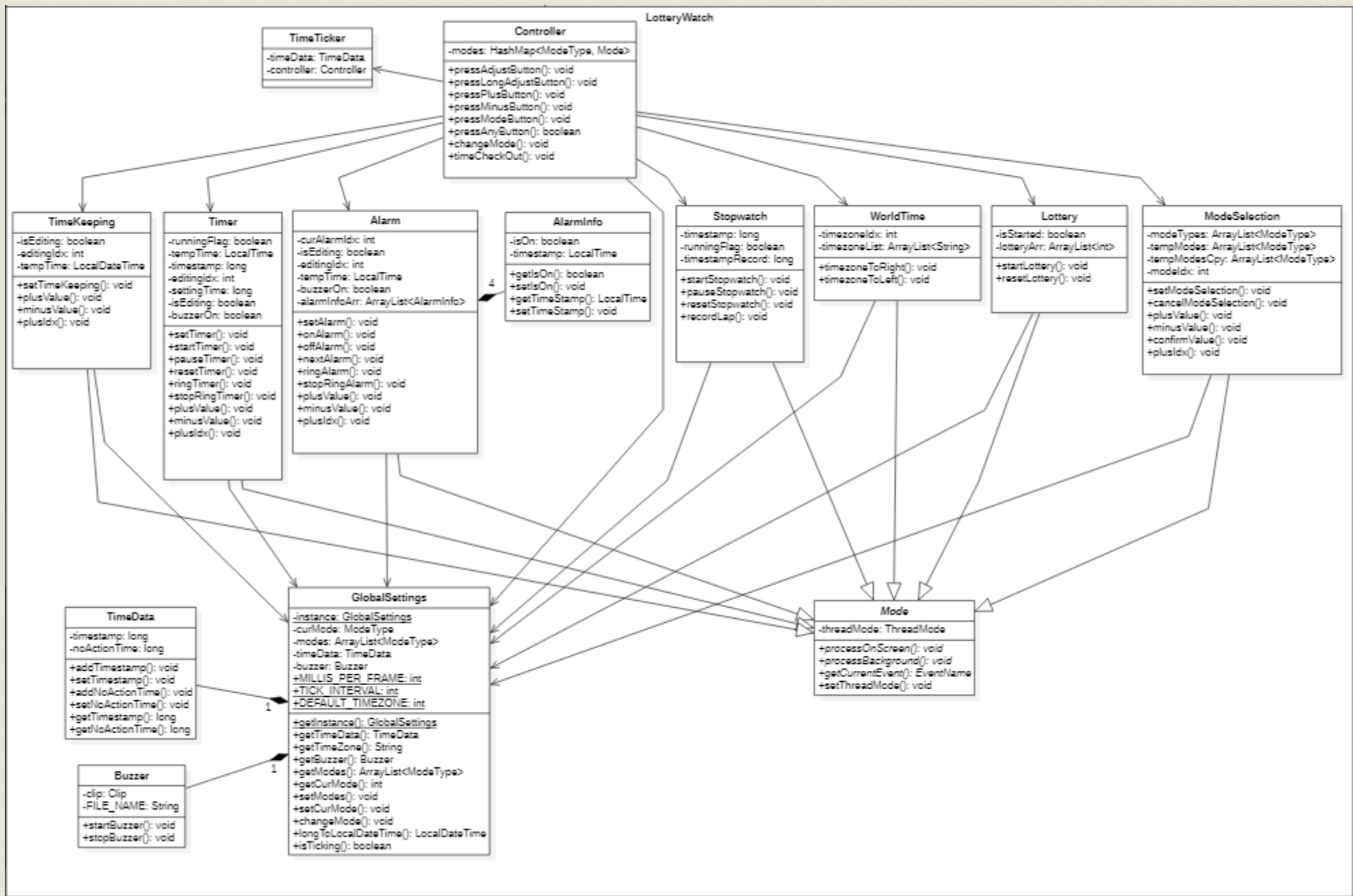

[2047] Perform 2040 Traceability Analysis

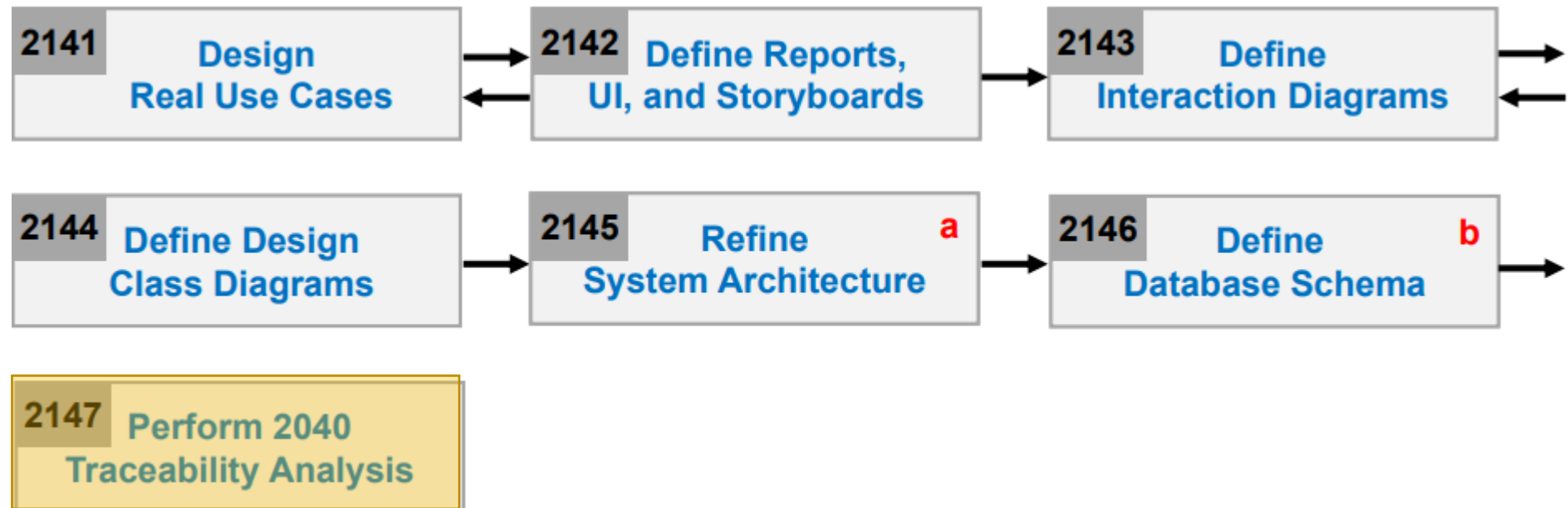

Use Case	S-Link
Set Timer	S1, S2, S3, S20, S33, S34, S35
Start Timer	S2, S23
Pause Timer	S2, S24
Reset Timer	S3, S25
Check Timer	S21
Ring Timer	S27, S39, S40
Stop Ring Timer	S26, S28, S39, S41
Show Timer	S22
Set Alarm	S1, S2, S3, S6, S7, S8 S33, S34, S35
On Alarm	S3, S37, S42
Off Alarm	S3, S37, S43
Next Alarm	S2, S38
Check Alarm	S7, S37, S44, S45
Ring Alarm	S27, S39, S40
Stop Ring Alarm	S9, S28, S39, S41
Show Alarm	S7, S44, S46

Use Case	S-Link
Start Stopwatch	S2, S12
Pause Stopwatch	S2, S13
Reset Stopwatch	S3, S14
Record Lap	S1, S15
Run Stopwatch	S47
Show Stopwatch	S46
Timezone to left	S3, S32
Timezone to right	S2, S31
Show Worldtime	S47
Set TimeKeeping	S1, S2, S3, S8, S33, S34, S35, S36, S48
Show TimeKeeping	S46
Start Lottery	S2, S9
Reset Lottery	S3, S10
Show Lottery	S46
Set Mode Selection	S1, S2, S3, S5, S16, S17, S18, S19, S33, S34, S35
Show Mode Selection	S46
Change Mode	S4, S29, S49, S50
Time Checkout	S30, S48, S50, S51, S52

SID	Operation in sequence diagram	M-Link
S1	pressAdjustButton()	M1, M6
S2	pressPlusButton()	M2, M6
S3	pressMinusButton()	M3, M6
S4	pressModeButton()	M4, M6
S5	pressLongModeButton()	M5, M6
S6	setAlarm()	M24
S7	getTimeStamp()	M35, M55
S8	setTimeStamp()	M36, M52
S9	stopRingAlarm()	M29, M23
S10	startLottery()	M49
S11	resetLottery()	M50
S12	startStopwatch()	M37
S13	pauseStopwatch()	M38
S14	resetStopwatch()	M39

SID	Operation in sequence diagram	M-Link
S15	recordLap()	M40
S16	getModes()	M65
S17	confirmValue()	M44, M47
S18	setModes()	M67
S19	setModeSelection()	M43
S20	setTimer()	M13
S21	checkTimer()	M22, M58
S22	showTimer()	M57, M61, M70, M71
S23	startTimer()	M14
S24	pauseTimer()	M15
S25	resetTimer()	M16
S26	stopRingTimer()	M18
S27	ringBuzzer()	M17, M22
S28	stopRingBuzzer()	M18, M23
S29	changeMode()	M7, M59, M60, M69
S30	timeCheckOut()	M8
S31	moveTimezoneRight()	M41, M63
S32	moveTimezoneLeft()	M42, M63

SID	Operation in sequence diagram	M-Link
S33	plusValue()	M10, M19, M30, M45
S34	minusValue()	M11, M20, M31, M46
S35	plusIdx()	M12, M21, M32 M48
S36	setTimeKeeping()	M9
S37	setIsOn()	M34
S38	nextAlarm()	M27
S39	getBuzzer()	M64
S40	startBuzzer()	M22
S41	stopBuzzer()	M23
S42	onAlarm()	M25
S43	offAlarm()	M26
S44	getIsOn()	M33
S45	ringAlarm()	M28
S46	processOnScreen()	M57
S47	processBackground()	M51, M53, M58
S48	getTimeData()	M62
S49	getCurMode()	M66
S50	setCurMode()	M68
S51	setNoActionTime()	M54
S52	getNoActionTime()	M56

MID	Method	Class
M1	pressAdjustButton()	Controller
M2	pressPlusButton()	
M3	pressMinusButton()	
M4	pressModeButton()	
M5	pressLongModeButton()	
M6	pressAnyButton()	
M7	changeMode()	
M8	timeCheckOut()	
M9	setTimeKeeping()	TimeKeeping
M10	plusValue()	
M11	minusValue()	
M12	plusIdx()	
M13	setTimer()	Timer
M14	startTimer()	
M15	pauseTimer()	
M16	resetTimer()	
M17	ringTimer()	
M18	stopRingTimer()	
M19	plusValue()	Buzzer
M20	minusValue()	
M21	plusIdx()	
M22	startBuzzer()	
M23	stopBuzzer()	

MID	Method	Class
M24	setAlarm()	Alarm
M25	onAlarm()	
M26	offAlarm()	
M27	nextAlarm()	
M28	ringAlarm()	
M29	stopRingAlarm()	
M30	plusValue()	
M31	minusValue()	
M32	plusIdx()	
M33	getIsOn()	
M34	setIsOn()	
M35	getTimeStamp()	
M36	setTimeStamp()	
M37	startStopwatch()	Stopwatch
M38	pauseStopwatch()	
M39	resetStopwatch()	
M40	recordLap()	WorldTime
M41	timezoneToRight	
M42	timezoneToLeft	ModeSelection
M43	setModeSelection()	
M44	cancelModeSelection()	
M45	plusValue()	
M46	minusValue()	
M47	confirmValue()	
M48	plusIdx()	

MID	Method	Class
M49	startLottery	Lottery
M50	resetLottery	
M51	addTimestamp	TimeData
M52	setTimestamp	
M53	addNoActionTime()	
M54	setNoActionTime()	
M55	getTimeStamp()	
M56	getNoActionTime	
M57	processOnScreen()	Mode
M58	processBackground()	
M59	getCurrentEvent()	
M60	setThreadMode()	
M61	getInstance()	GlobalSettings
M62	getTimeData()	
M63	getTimeZone()	
M64	getBuzzer()	
M65	getModes()	
M66	getCurMode()	
M67	setModes()	
M68	setCurMode()	
M69	changeMode()	
M70	longToLocalDateTime()	
M71	isTicking()	

OOPT Stage 2040 Design



감사합니다

